

Frequency Inverter

CFW700

User's Manual

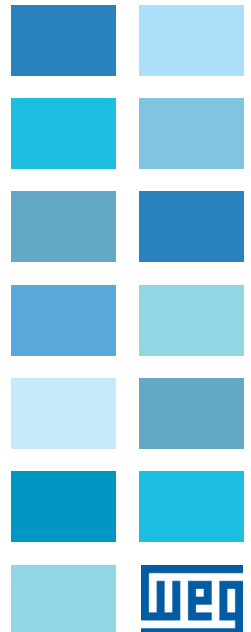



User's Manual

Series: CFW700

Language: English

Document: 10000771684 / 05

Models: Frame Sizes A...E

Date: 01/2018

Summary of Revisions

The table below describes the revisions made to this manual.

Version	Review	Description
-	R01	First edition
-	R02	Cover update
-	R03	General revision
-	R04	Inclusion of new frame sizes models D and E Update from IP54 to IP55 in frame sizes B and C
-	R05	General revision



ATTENTION!

Parameters P0296 (Rated Line Voltage), P0400 (Rated Motor Voltage) and P0403 (Rated Motor Frequency), were readjusted at the:

- 200...240 V / 220 / 230 V (S2, B2 and T2) models: P0296 = 0 (200 / 240 V), P0400 = 220 V and P0403 = 60 Hz.
- 380...480 V (T4) models: P0296 = 3 (440 / 460 V), P0400 = 440 V and P0403 = 60 Hz.
- 500...600 V (T5) models: P0296 = 6 (550 / 575 V), P0400 = 575 V and P0403 = 60 Hz.

For different values of line rated voltage and/or motor voltage and frequency, set these parameters through the STARTUP menu, as presented in the user's manual [Section 5.2 START-UP on page 49](#).

1	SAFETY INSTRUCTIONS	1
1.1	SAFETY WARNINGS IN THE MANUAL.....	1
1.2	SAFETY WARNINGS IN THE PRODUCT.....	1
1.3	PRELIMINARY RECOMMENDATIONS	2
2	GENERAL INSTRUCTIONS	3
2.1	ABOUT THE MANUAL	3
2.2	ABOUT THE CFW700	3
2.3	IDENTIFICATION	6
2.4	LIST OF AVAILABLE MODELS	8
2.5	IDENTIFICATION LABELS	8
2.6	RECEIVING AND STORAGE	9
3	INSTALLATION AND CONNECTION.....	10
3.1	MECHANICAL INSTALLATION	10
3.1.1	Installation Environment	10
3.1.2	Mounting Considerations.....	10
3.2	ELECTRICAL INSTALLATION	11
3.2.1	Identification of the Power and Grounding Terminals.....	12
3.2.2	Power / Grounding Wiring and Fuses	14
3.2.3	Power Connections	15
3.2.3.1	Input Connections.....	16
3.2.3.2	Power Supply Capacity	16
3.2.3.3	Dynamic Braking (standard built-in for frame sizes A, B, C and D and optional built-in for frame size E - CFW700...DB...)	16
3.2.3.4	Output Connections.....	18
3.2.4	Grounding Connections	19
3.2.5	Control Connections	20
3.2.6	Cable Distances	24
3.3	INSTALLATION ACCORDING TO THE EUROPEAN DIRECTIVE OF ELECTROMAGNETIC COMPATIBILITY	24
3.3.1	Conformal Installation	24
3.3.2	Emission and Immunity Levels	25
4	KEYPAD (HMI) AND BASIC PROGRAMMING	26
4.1	INTEGRAL KEYPAD - HMI-CFW700	26
4.2	APPLICATIONS.....	29
4.2.1	PID Regulator Application.....	29
4.2.1.1	Academic PID	33
4.2.2	Electronic Potentiometer Application (E.P.)	39
4.2.3	Multispeed Application	41
4.2.4	3-Wire Start/Stop Command Application	44
4.2.5	Forward/Reverse Run Application	46

5	FIRST TIME POWER-UP AND START-UP	49
5.1	PREPARE FOR START-UP	49
5.2	START-UP.....	49
5.2.1	Oriented Start-up Menu	50
5.2.2	Basic Application Menu	53
6	TROUBLESHOOTING AND MAINTENANCE	54
6.1	FAULTS AND ALARMS.....	54
6.2	SOLUTIONS FOR THE MOST FREQUENT PROBLEMS.....	54
6.3	INFORMATION FOR CONTACTING TECHNICAL SUPPORT	55
6.4	PREVENTIVE MAINTENANCE	56
6.5	CLEANING INSTRUCTIONS	57
7	OPTION KITS AND ACCESSORIES.....	59
7.1	OPTION KITS.....	59
7.1.1	Built-in RFI Filter (only for frame sizes A, B, C and D) - CFW700...C3.....	59
7.1.2	Dynamic Braking IGBT (only for frame size E in 220 / 230 V and 380...480 V models and for frame sizes D and E in 500...600 V models) - CFW700...DB...	59
7.1.3	Nema1 Protection Degree (only for frame sizes A, B, C and E) - CFW700...N1.....	59
7.1.4	IP55 Protection Degree (only for frame sizes B and C) - CFW700...55.....	59
7.1.5	IP21 Protection Degree (only for frame sizes A, B and C) - CFW700...21.....	59
7.1.6	STO Function - CFW700...Y1.....	59
7.1.7	24 Vdc External Control Power Supply - CFW700...W1.....	60
7.2	ACCESSORIES	60
8	TECHNICAL SPECIFICATIONS.....	62
8.1	POWER DATA	62
8.2	ELECTRICAL/GENERAL SPECIFICATIONS	63
8.3	CODES AND STANDARDS	65
8.4	CERTIFICATIONS	65

1 SAFETY INSTRUCTIONS

This manual provides information for the proper installation and operation of the CFW700 frequency inverter.

Only trained personnel, with proper qualifications, and familiar with this kind of equipment and associated machinery shall plan and implement the installation, starting, operation, and maintenance of this equipment. The personnel shall follow all the safety instructions described in this manual and/or defined by the local regulations. Failure to comply with the safety instructions may result in death, serious injury, and equipment damage.

1.1 SAFETY WARNINGS IN THE MANUAL



DANGER!

The procedures recommended in this warning have the purpose of protecting the user against death, serious injuries and considerable material damage.



ATTENTION!

The procedures recommended in this warning have the purpose of avoiding material damage.



NOTE!

The text intends to supply important information for the correct understanding and good operation of the product.

1.2 SAFETY WARNINGS IN THE PRODUCT

The following symbols are attached to the product, serving as safety notices:



High voltages are present.



Components sensitive to electrostatic discharge.
Do not touch them.



Mandatory connection to the protective ground (PE).



Connection of the shield to the ground.



Hot surface.

1.3 PRELIMINARY RECOMMENDATIONS

**DANGER!**

Always disconnect the main power supply before touching any electrical device associated with the inverter. Several components may remain charged with high voltage and/or in movement (fans), even after the AC power supply has been disconnected or turned off. Wait at least 10 minutes to guarantee the fully discharge of capacitors. Always connect the equipment frame to the ground protection (PE).

**NOTE!**

- Frequency inverters may cause interference in other electronic devices. Follow the recommendations listed in [Chapter 3 INSTALLATION AND CONNECTION on page 10](#), to minimize these effects.
- Fully read this manual before installing or operating the inverter.

**Do not perform a withstand voltage test on any part of the inverter!
If needed, please, consult WEG.**

**DANGER!****Crushing Hazard**

In order to ensure safety in load lifting applications, electric and/or mechanical devices must be installed outside the inverter for protection against accidental fall of load.

**DANGER!**

This product was not designed to be used as a safety element. Additional measures must be taken so as to avoid material and personal damages. The product was manufactured under strict quality control, however, if installed in systems where its failure causes risks of material or personal damages, additional external safety devices must ensure a safety condition in case of a product failure, preventing accidents.

**ATTENTION!**

When in operation, electric energy systems - such as transformers, converters, motors and cables - generate electromagnetic fields (EMF), posing a risk to people with pacemakers or implants who stay in close proximity to them. Therefore, those people must stay at least 2 meters away from such equipment.

2 GENERAL INSTRUCTIONS

2.1 ABOUT THE MANUAL

The purpose of this manual is to provide the basic information needed to install, start-up in the V/f control mode (scalar), and troubleshoot the most common problems of the CFW700 frequency inverter series.



ATTENTION!

The operation of this equipment requires installation instructions and detailed operation provided in the user's manual, programming manual and manuals/guides for kits and accessories. The user's manual and the parameters quick reference are supplied in a hard copy together with the inverter. The user guides are also provided in a hard copy along with the kit/accessories.

Some of the figures and tables are available in the appendixes. The [APPENDIX A - DIAGRAMS AND FIGURES on page 207](#) shows the figures and the [APPENDIX B - TECHNICAL SPECIFICATIONS on page 218](#) shows the technical specifications. The information is available in three languages.

Please refer to the following technical manuals for further information:

- CFW700 Programming Manual.
- DeviceNet Communication Manual.
- CANopen Communication Manual.
- Profibus DP Communication Manual.
- Modbus Communication Manual.
- SoftPLC Manual.

2.2 ABOUT THE CFW700

The CFW700 frequency inverter is a high performance product designed for speed and torque control of threephase induction motors. The main characteristic of this product is the “Vectrue” technology, which has the following advantages:

- Scalar control (V/f), VVW or vector control programmable in the same product.
- The vector control may be programmed as “sensorless” (which means standard motors without using encoders) or as “vector control” with the use of an encoder.
- The “sensorless” control allows high torque and fast response, even in very low speeds or at the starting.
- The “vector with encoder” control allows high speed precision for the whole speed range (even with a standstill motor).

General Instructions

- “Optimal Braking” function for the vector control, allowing the controlled braking of the motor and avoiding external braking resistor for some applications.
- “Self-Tuning” feature for vector control. It allows the automatic adjustment of the regulators and control parameters from the identification (also automatic) of the motor parameters and load.

The main components of the CFW700 can be viewed in [Figure A.1 on page 207](#).

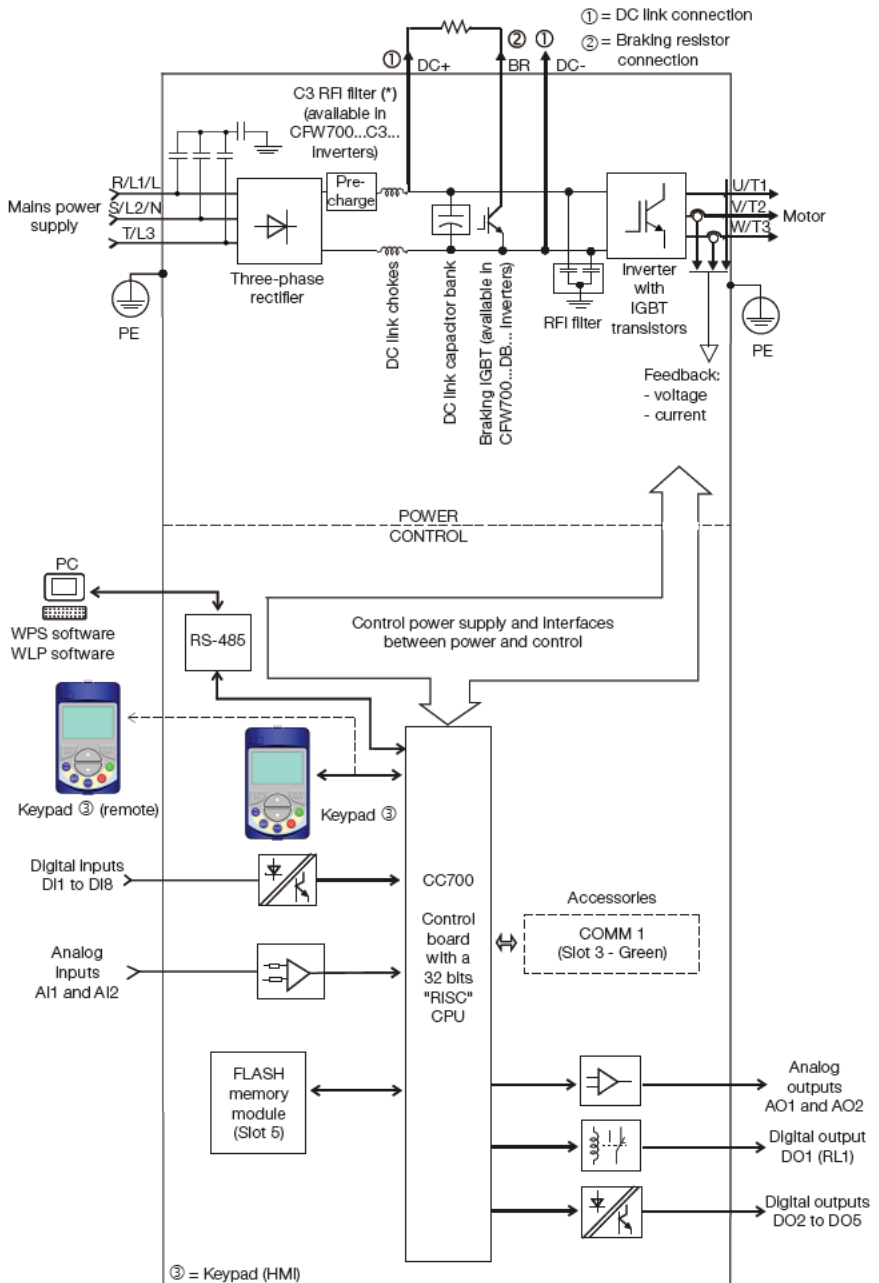

Figure 2.1: Block diagram for the CFW700

2.3 IDENTIFICATION

Table 2.1: Identification of the CFW700 inverters

Product and Series	Model Identification			Enclosure (1)	Conducted Emission Level (1)	Discon. Switch (5)	Safety Stop (3)	External Control Voltage	Special Hardware Version	Special Software Version
	Frame Size	Rated Output Current	Number of Power Phases							
Eg.: CFW700	A	03P6	T	20	C3	DS	Y1	W1	---	--
CFW700	Refer to Table 2.2 on page 7 .			DB	C3	Blank = not available DS = with discon. switch	Y1	W1	---	Blank = standard. Sx = special software.
	NB = without dynamic braking (valid only for frame size E inverters).									
	DB = with dynamic braking. 20 = IP20. (6)									
	21 = IP21 (not available for frame size E inverters).									
	N1 = Nema1 enclosure (UL Type 1) (protection degree according to IEC: IP21 for frame sizes A, B and C and IP20 for frame sizes D and E).									
55 = IP55 (only for 200...240 V and 380...480 V models of frame sizes B, C, D and E).										
Blank = it is not in accordance with the standard conducted emission levels. C3 = according to category 3 (C3) of IEC 61800-3, with built-in C3 RFI filter. (4)										
Available options										

Notes:

- (1) The options available for each model are shown in [Table 2.2 on page 7](#).
- (2) This option is not available for frame size D inverters (the standard product is Nema1).
- (3) This option is not available for frame size A inverters with the N1 option (Nema1 enclosure) or IP21.
- (4) It is possible to meet the requirements of category C2 with this filter on mechanics A models. For further details, see [Table B.7 on page 234](#).
- (5) Only applicable to models with degree of protection IP55.

Table 2.2: Options available for each model according to the size, power supply, rated current and voltage of the inverter

Frame Size	Rated Output Current for ND Overload	Number of Power Phases	Rated Voltage	Available Options for the Remaining Identification Codes of the Inverters (standard product is shown in bold)			
				Braking	Enclosure (Protection Degree)	Discon. Switch	Conducted Emission Level
A (IP20) B (IP55)	06P0 = 6.0 A	B = single-phase or three-phase	2 = 200...240 V	DB	20, 21, N1 or 55		Blank
	07P0 = 7.0 A						
A (IP20) B (IP55)	06P0 = 6.0 A	S = Single-phase	2 = 200...240 V	DB	20, 21, N1 or 55	Blank	C3
	07P0 = 7.0 A						Blank or C3
	10P0 = 10 A						
A (IP20) B (IP55)	07P0 = 7.0 A	T = three-phase	2 = 200...240 V	DB	20, 21, N1 or 55	Blank or DS	Blank or C3
	10P0 = 10 A						
	13P0 = 13 A						
	16P0 = 16 A						
B	24P0 = 24 A						
	28P0 = 28 A						
	33P5 = 33.5 A						
C	45P0 = 45 A						
	54P0 = 54 A						
	70P0 = 70 A						
D	86P0 = 86 A						
	0105 = 105 A						
E	0142 = 142 A	2 = 220...230 V	NB or DB	20, N1 or 55	Blank or DS	C3	
	0180 = 180 A						
	0211 = 211 A						
A (IP20) B (IP55)	03P6 = 3.6 A	T = three-phase	4 = 380 / 480 V	DB	20, 21, N1 or 55	Blank	Blank or C3
	05P0 = 5.0 A						
	07P0 = 7.0 A						
	10P0 = 10 A						
B	13P5 = 13.5 A						
	17P0 = 17 A						
	24P0 = 24 A						
C	31P0 = 31 A						
	38P0 = 38 A						
	45P0 = 45 A						
D	58P5 = 58.5 A						
	70P5 = 70.5 A						
	88P0 = 88 A						
E	0105 = 105 A						
	0142 = 142 A						
	0180 = 180 A						
	0211 = 211 A						
B	02P9 = 2.9 A	T = three-phase	5 = 500...600 V	DB	20, 21 or N1	Blank	Blank or C3
	04P2 = 4.2 A						
	07P0 = 7.0 A						
10P0 = 10 A							
C	12P0 = 12 A						
	17P0 = 17 A						
	22P0 = 22 A						
D	27P0 = 27 A						
	32P0 = 32 A						
	44P0 = 44 A						
E	22P0 = 22 A						
	27P0 = 27 A						
	32P0 = 32 A						
	44P0 = 44 A						
	53P0 = 53 A						
	63P0 = 63 A						
E	80P0 = 80 A						
	0107 = 107 A						
	0125 = 125 A						
	0150 = 150 A						

2.4 LIST OF AVAILABLE MODELS

The available inverter models are listed in [Table B.1 on page 218](#), [Table B.2 on page 219](#) and [Table B.3 on page 220](#).

2.5 IDENTIFICATION LABELS

There are two nameplates on the CFW700: one complete nameplate is affixed to the side of the inverter and a simplified one is located under the keypad. Please refer to [Figure A.2 on page 208](#) to verify the position of these labels on the product. The nameplate under the keypad allows the identification of the most important characteristics of the inverter even if they are mounted side-by-side. When there is more than one inverter it is necessary to be careful not to exchange the inverter covers (front cover in case of inverters frame sizes A, B or C and control rack cover for inverters frame sizes D and E) because there are individual information labels under the keypad of each inverter.

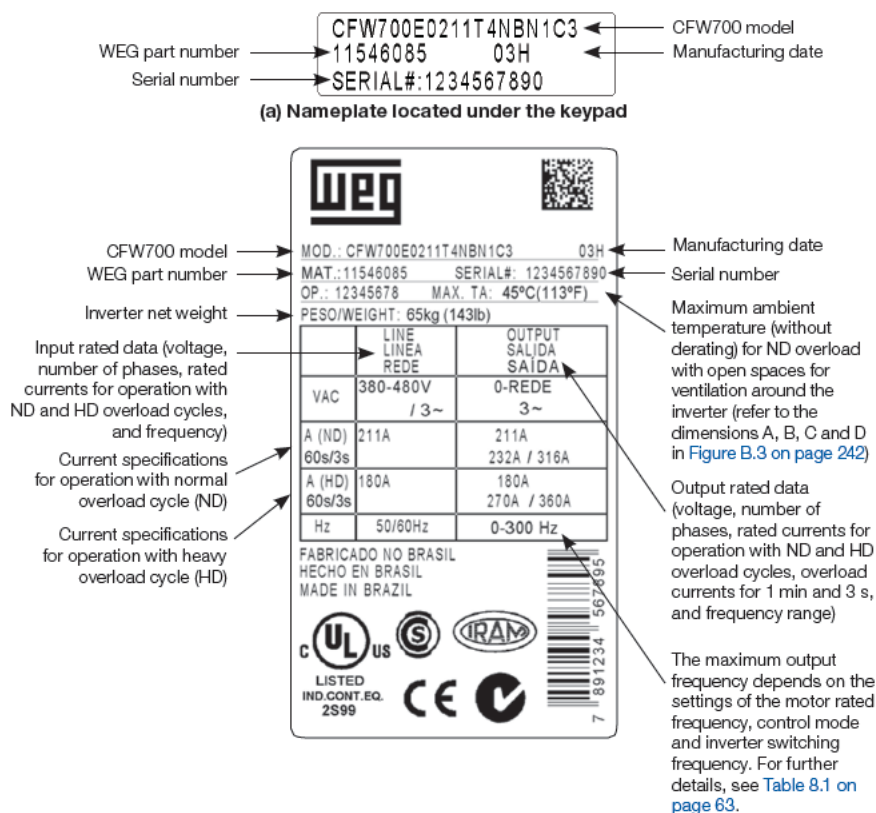

2.6 RECEIVING AND STORAGE

The CFW700 comes packaged in a cardboard box up to frame size C inverter models. The bigger models are packed in wooden box. There is an identification label affixed to the outside of this package, the same one that is affixed to the side of the CFW700 inverter.

Follow the steps below to open the packaging of models larger than frame size C:

1. Put the shipping container over a flat and stable area with the assistance of another two people.
2. Open the wood crate.
3. Remove all the packing material (the cardboard or styrofoam protection) before removing the inverter.

Check the following items once the inverter is delivered:

- Verify that the CFW700 nameplate corresponds to the model number on your purchase order.
- Inspect the CFW700 for external damage during transportation.

Report any damage immediately to the carrier that delivered your CFW700 inverter.

If CFW700 is to be stored for some time before use, be sure that it is stored in a clean and dry location that conforms to the storage temperature specification (between -25 °C and 60 °C (-13 °F and 140 °F)). Cover the inverter to prevent dust accumulation inside it.



ATTENTION!

Capacitor reforming is required if drives are stored for long periods of time without power. Refer to [Section 6.4 PREVENTIVE MAINTENANCE on page 56](#).

3 INSTALLATION AND CONNECTION

3.1 MECHANICAL INSTALLATION

3.1.1 Installation Environment

Avoid installing the inverter in an area with:

- Direct exposure to sunlight, rain, high humidity, or sea-air.
- Inflammable or corrosive gases or liquids.
- Excessive vibration.
- Dust, metallic particles, and oil mist.

Environment conditions for the operation of the inverter:

- Inverter surrounding temperature: from -10 °C up to Ta according to the [Table B.5 on page 223](#).
- A current derating of 2 % is necessary for each degree Celsius above Ta up to a limit of:
 - 60 °C for models of frames A, B, C and D with IP2X or Nema1 degree of protection.
 - 55 °C for models of frame E with IP2X or Nema1 degree of protection.
 - 50 °C for all models with IP55 degree of protection.
- Humidity: from 5 % to 95 % non-condensing.
- Altitude: up to 1000 m (3,300 ft) - standard conditions (no derating required).
- From 1000 m to 4000 m (3,300 ft to 13,200 ft) - current derating of 1 % each 100 m (or 0.3 % each 100 ft) above 1000 m (3,300 ft) altitude.
- From 2000 m to 4000 m (6,600 ft to 13,200 ft) above sea level - maximum voltage reduction (240 V for 200...240 V models, 230 V for 220...230 V models, 480 V for 380...480 V models and 600 V for 500...600 V models) of 1.1 % for each 100 m (330 ft) above 2000 m (6,600 ft).
- Pollution degree: 2 (according to EN50178 and UL508C) with non-conductive pollution. Condensation shall not originate conduction through the accumulated residues.

3.1.2 Mounting Considerations

External dimensions, fixing holes position and net weight of the inverter are presented at [Figure B.2 on page 240](#) and [Figure B.3 on page 242](#). Please refer to [Figure B.4 on page 243](#) to [Figure B.11 on page 250](#) for more details of each inverter size.

Install the inverter upright on a flat surface. First place the screws on the surface where the drive is going to be installed, install the drive and then tighten the screws.

Frame size E inverters with N1 option (CFW700E...N1...):

- After fixing the inverter, install the upper Nema 1 kit on the inverter using the two M8 screws provided with the product.

Let the minimum clearances specified in [Figure B.3 on page 242](#) in order to allow air circulation for cooling. It is possible to assembly frame sizes A, B and C inverters with IP20 protection degree (CFW700... 20...) side by side without lateral spacing, i.e., with the D distance presented in [Figure B.3 on page 242](#) equal to zero.

Do not install heat sensitive components right above the inverter.

**ATTENTION!**

- When arranging two or more inverters vertically, respect the minimum clearance A + B ([Figure B.3 on page 242](#)) and provide an air deflecting plate so that the heat rising up from the bottom inverter does not affect the top inverter.
- Provide conduit for physical separation of the signal, control, and power conductors (refer to [Section 3.2 ELECTRICAL INSTALLATION on page 11](#)).

Please refer to [Figure B.3 on page 242](#) for surface and flange mounting data. The inverter dissipated power at rated condition for surface and flange mounting is presented in [Table B.5 on page 223](#). Remove the drive mounting brackets for flange mounting. The protection degree of the inverter outside the panel is IP55 for flange mounting. It is necessary to provide proper seal for the opening where the inverter is installed to ensure the protection degree of the panel. Example: sealing with silicone.

Please refer to [Figure A.4 on page 210](#) for more details on the access to the control and power terminals.

3.2 ELECTRICAL INSTALLATION

**DANGER!**

- The following information is merely a guide for proper installation. Comply with applicable local regulations for electrical installations.
- Make sure the AC power supply is disconnected before starting the installation.

3.2.1 Identification of the Power and Grounding Terminals

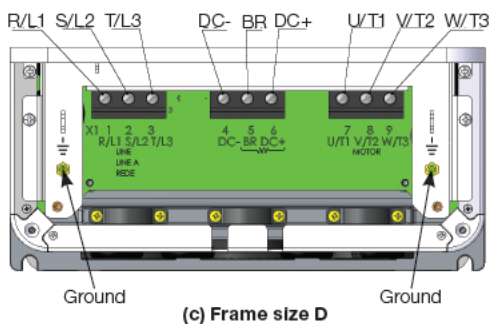
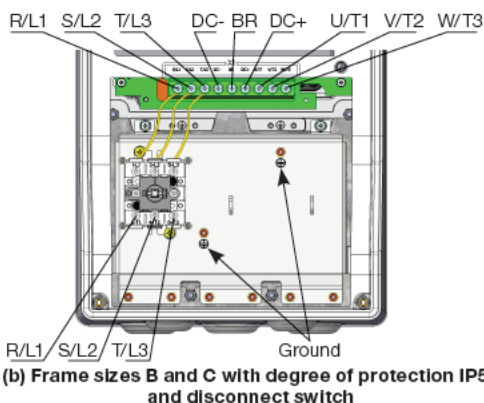
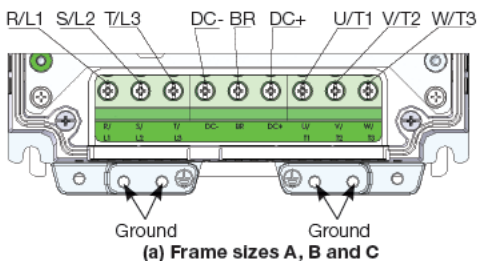

R/L1, S/L2, T/L3: AC power supply.
DC-: this is the negative potential terminal in the DC link circuit.
BR: braking resistor connection.
DC+: this is the positive potential terminal in the DC link circuit.
U/T1, V/T2, W/T3: motor connection.

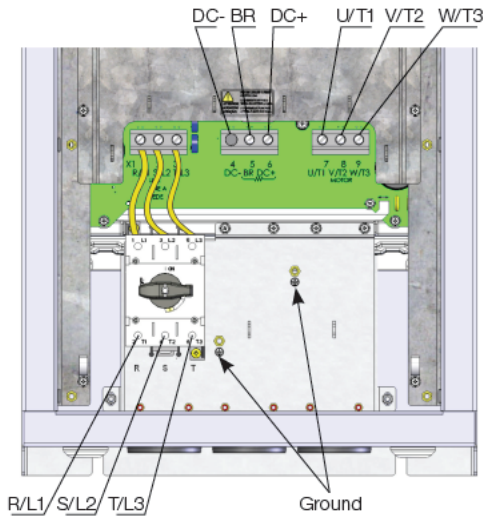

(d) Frame size D with degree of protection IP55

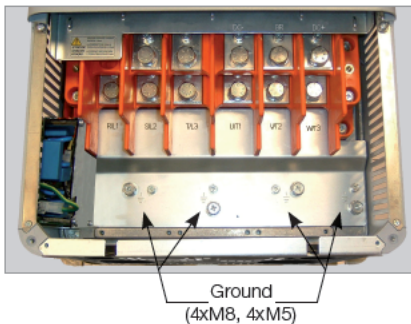

(e) Frame size E

R/L1, S/L2, T/L3: AC power supply.

U/T1, V/T2, W/T3: motor connection.

DC+: this is the positive potential terminal in the DC link circuit.

BR: braking resistor connection.

DC-: this is the negative potential terminal in the DC link circuit.

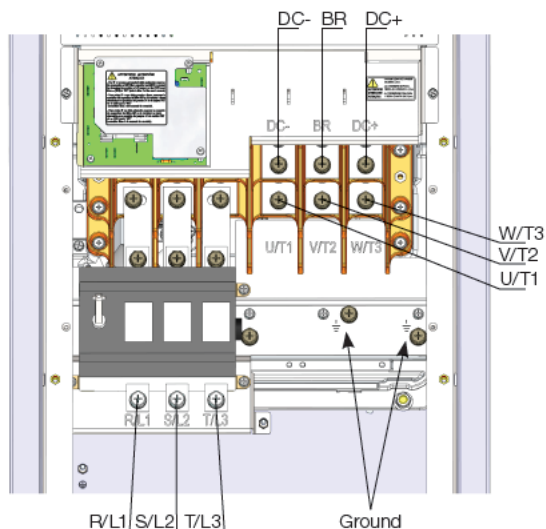
(f) Frame size E with degree of protection IP55
Figure 3.1: (a) to (f) Power terminals and grounding points - frame sizes A to E

3.2.2 Power / Grounding Wiring and Fuses

ATTENTION!

Use proper cable lugs for the power and grounding connection cables.

ATTENTION!

Residual Current Device (RCD):

- When installing an RCD to guard against electrical shock, only devices with a trip current of 300 mA should be used on the supply side of the inverter.
- Depending on the installation (motor cable length, cable type, multimotor configuration, etc.), the RCD protection may be activated. Contact the RCD manufacturer for selecting the most appropriate device to be used with inverters.

Refer to [Table B.1 on page 218](#), [Table B.2 on page 219](#) and [Table B.3 on page 220](#) for the recommended wiring and fuses and [Table B.6 on page 231](#) for the specifications of the power terminals.

NOTE!

The gauges values presented in [Table B.1 on page 218](#), [Table B.2 on page 219](#) and [Table B.3 on page 220](#) are for reference only. Installation conditions and the maximum permitted voltage drop shall be considered for the proper wiring sizing.

Input fuses

- The fuses to be used at the input must be HS (High-Speed) type with I^2t equal or lower the value indicated in the [Table B.1 on page 218](#), [Table B.2 on page 219](#) and [Table B.3 on page 220](#) (consider extinction current value in cold situation (it is not the fusion value)), to protect the inverter diode rectifiers and input wiring.
- In order to meet UL requirements, use class J fuses at the inverter supply with a current not higher than the values presented in [Table B.1 on page 218](#), [Table B.2 on page 219](#) and [Table B.3 on page 220](#).
- Optionally, slow blow fuses can be used at the input. They shall be sized for 1.2 x the rated input current of the inverter. In this case, the installation is protected against short-circuit, but not the inverter input rectifier. This may result in major damage to the inverter in the event of an internal component failure.

3.2.3 Power Connections

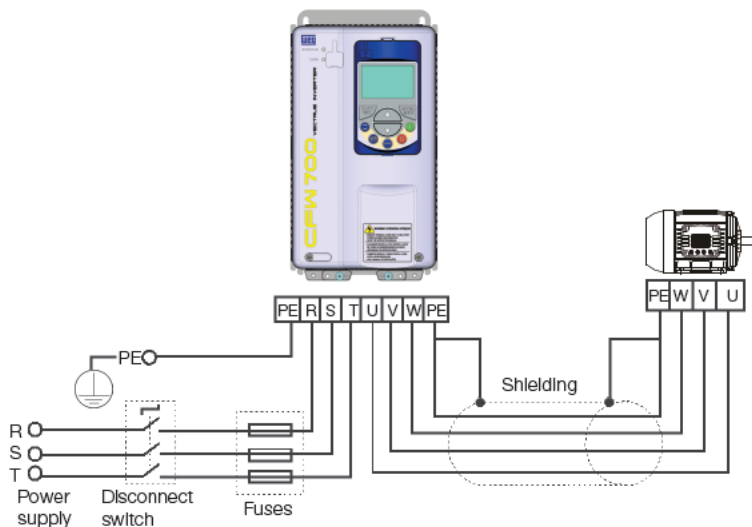

Figure 3.2: Power and grounding connections

- The switch-disconnector is not necessary if the inverter has the DS optional item (with switch-disconnector).

3.2.3.1 Input Connections

DANGER!

Provide a disconnect device for the input power supply of the inverter. This device shall disconnect the input power supply for the inverter when needed (for instance, during servicing).

ATTENTION!

The power supply that feeds the inverter shall have a solid grounded neutral. In case of IT networks, follow the instructions described below.

ATTENTION!

In order to be able to use the CFW700 with built-in C3 RFI filter (frame sizes A, B, C and D with optional RFI filter and all frame size E inverter models - CFW700...C3...) in IT networks (neutral conductor not grounded or grounded via a high ohmic value resistor) or in corner-grounded delta systems, it is necessary to remove some RFI filter components (capacitor for frame sizes A, B, C and D and capacitor and the MOV for frame size E) connected to the ground by removing the screws indicated in [Figure A.8 on page 214](#) for inverter frame sizes A, B, C and D and changing the position of the J1 jumper on the PRT1 board from \oplus (XE1) to "NC" (XIT), according to the [Figure A.8 on page 214](#) for inverter frame size E.

3.2.3.2 Power Supply Capacity

Suitable for circuits with capacity to deliver no more than:

- 100 kA symmetric at 240 V, 480 V or 600 V when the inverter is protected by fuses.
- 65 kA symmetric at 240 V or 480 V when the inverter is protected by reverse-type circuit breakers.
- 14 kA symmetric at 600 V when the inverter is protected by reverse-type circuit breakers.

For compliance with UL standard and specification of current of fuses and circuit breaker see [Table B.1 on page 218](#) to [Table B.3 on page 220](#).

In case the CFW700 is installed in power supplies with current capacity higher than 100.000 A_{ms}, it is necessary to provide adequate protections circuits such as fuses or switches.

3.2.3.3 Dynamic Braking (standard built-in for frame sizes A, B, C and D and optional built-in for frame size E - CFW700...DB...)

Refer to [Table B.1 on page 218](#), [Table B.2 on page 219](#) and [Table B.3 on page 220](#) for the following dynamic braking specifications: maximum current, resistance, RMS current (*) and cable gauges.

The power rating of the dynamic braking resistor is a function of the deceleration time, the load inertia and the resistant torque.

Dynamic braking installing procedure:

- Install the braking resistor between the power terminals DC+ and BR.
- Use twisted cable for the connection. Separate these cables from the signal and control cables.
- Size the cables according to the application, respecting the maximum and effective currents.
- If the braking resistor is installed inside the inverter cabinet, consider its additional dissipated energy when sizing the cabinet ventilation.
- The thermal protection of the dynamic braking resistor must be provided externally using a thermal relay in series with the resistor and/or a thermostat in contact with the resistor frame, connected so as to switch the input power supply of the inverter, as shown in [Figure 3.3 on page 17](#).
- Set P0151 and P0185 to their maximum values (400 V or 800 V) when using dynamic braking.
- The DC link voltage actuation level of the dynamic braking is set by parameter P0153 (Dynamic Braking Level).

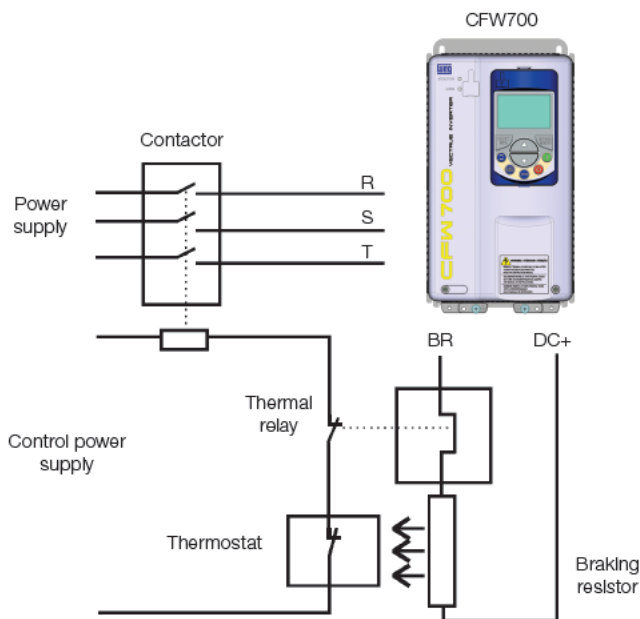

Figure 3.3: Connection of the braking resistor

(*) The effective braking current can be calculated as follows:

$$I_{\text{effective}} = \frac{I_{\text{max}} \cdot \sqrt{t_{\text{br}} (\text{min})}}{5}$$

3.2.3.4 Output Connections

ATTENTION!

- The inverter has an electronic motor overload protection that shall be adjusted according to the driven motor. When several motors are connected to the same inverter, install individual overload relays for each motor.
- The motor overload protection available for the CFW700 is in accordance with UL508C as per the following information:
 - "Trip" current equal to 1.25 times the motor rated current (P0401) adjusted in the "Oriented Start-up" menu.
 - The maximum value of P0398 (Motor Service Factor) is 1.15.
 - Parameters P0156, P0157 and P0158 (Overload Current at 100 %, 50 % and 5 % of the rated speed, respectively) are automatically adjusted when the parameters P0401 (Motor Rated Current) and/or P0406 (Motor Ventilation) are changed on the "Oriented Start-up" menu. If the parameters P0156, P0157 and P0158 are set manually, the maximum allowed value is $1.05 \times P0401$.

ATTENTION!

If a disconnect switch or a contactor is installed between the inverter and the motor, never operate them with a spinning motor or with voltage at the inverter output.

The characteristics of the cable used for the inverter and motor interconnection, as well as the physical location are extremely important to avoid electromagnetic interference in other equipment and to not affect the life cycle of motor windings and motor bearings controlled by inverters.

Keep motor cables away from other cables (signal cables, sensor cables, control cables, etc.), according to [Item 3.2.6 Cable Distances on page 24](#).

Connect a fourth cable between the motor ground and the inverter ground.

When using shielded cables for connecting the motor:

- Follow the recommendations of IEC60034-25.
- Use low impedance connection to high frequencies to connect the cable shield to ground. Using parts supplied with the drive. See item below.
- For inverter frame sizes A, B and C there is an accessory called "Shielding kit for power cables PCSx-01" (see [Section 7.2 ACCESSORIES on page 60](#)), which can be mounted at the bottom of the cabinet - the [Figure 3.4 on page 19](#) shows an example. The shielding kit for power cables PCSx-01 goes along with inverters with optional internal C3 RFI filter (CFW700...C3...). The grounding for the motor cable shield on inverter frame sizes D and E is already provided in the standard inverter cabinet. This is also provided on the "Nema1 Kits (KN1x-01)" of the inverter frame sizes A, B and C.
- For frame sizes B and C with degree of protection IP55, the accessory "PCSC-03 power cable shield kit" is available, and for frame size D and E with degree of IP55 use the standard accessories for shielding. The PCSC-03 shield kit comes with the inverter as optional item 55.



Figure 3.4: Motor cable shielding connection with PCSx-01 accessory

3.2.4 Grounding Connections



DANGER!

- The inverter shall be connected to a Protective Ground (PE).
- Use the minimum ground wiring gauge as indicated in the [Table B.1 on page 218](#), [Table B.2 on page 219](#) and [Table B.3 on page 220](#).
- Connect the inverter grounding connections to a ground bus bar, to a single ground point, or to a common grounding point (impedance $\leq 10 \Omega$).
- The neutral conductor of the network shall be solidly grounded; however, this conductor shall not be used to ground the inverter.
- It is necessary to use a copper cable with 10 mm² minimum or 2 cables with the same wire gauge as specified in [Table B.1 on page 218](#), [Table B.2 on page 219](#) and [Table B.3 on page 220](#) for connecting the inverter to the ground protection to be in accordance with IEC61800-5-1 since the leakage current is greater than 3.5 mA AC.

3.2.5 Control Connections

The control connections (analog inputs/outputs and digital inputs/outputs), shall be performed in connector XC1 of the CC700 Control Board. Functions and typical connections are presented in [Figure 3.5 on page 21](#).

English

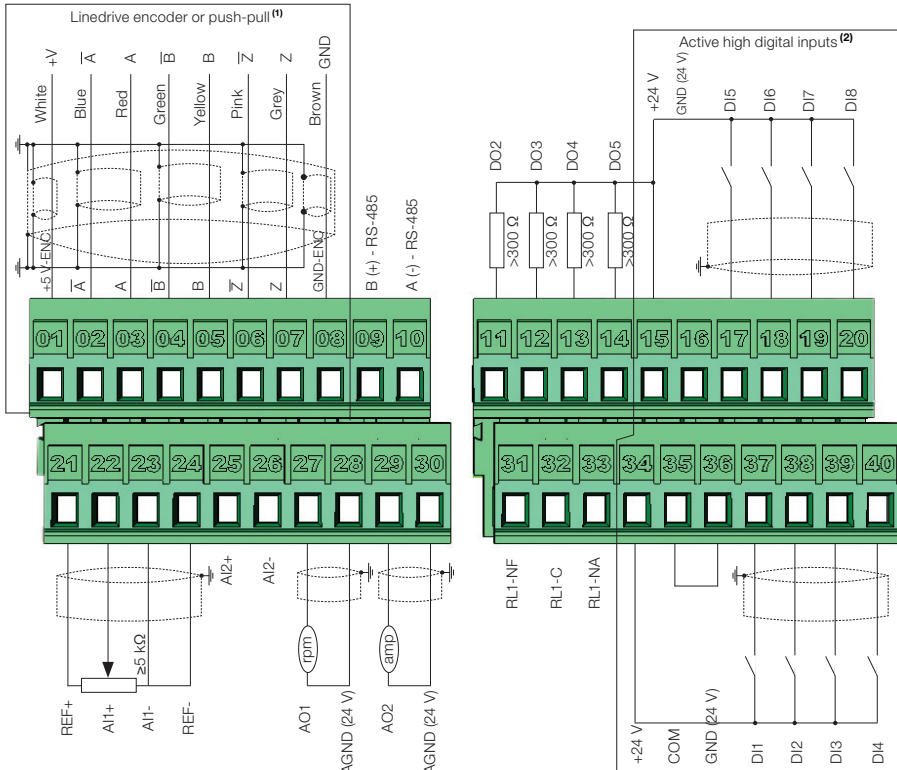

- (1) Refer to [Figure 3.5 on page 21](#) (b) for the open-collector encoder connection.
 (2) Refer to [Figure 3.5 on page 21](#) (c) for active low digital inputs connection.

(a) Linedrive encoder or push-pull and active high digital inputs



Figura 3.5: (a) to (c) XC1 connection terminals



Figura 3.6: Sequence of the encoder signals

Refer to [Figure A.3 on page 208](#) to find the control board, the XC1 connector (control signals), the S1 DIP-switches (to select the type of signal of the analog inputs and outputs) and S2 (RS-485 network termination) and slots 3 and 5 for accessories (see [Section 7.2 ACCESSORIES on page 60](#)).

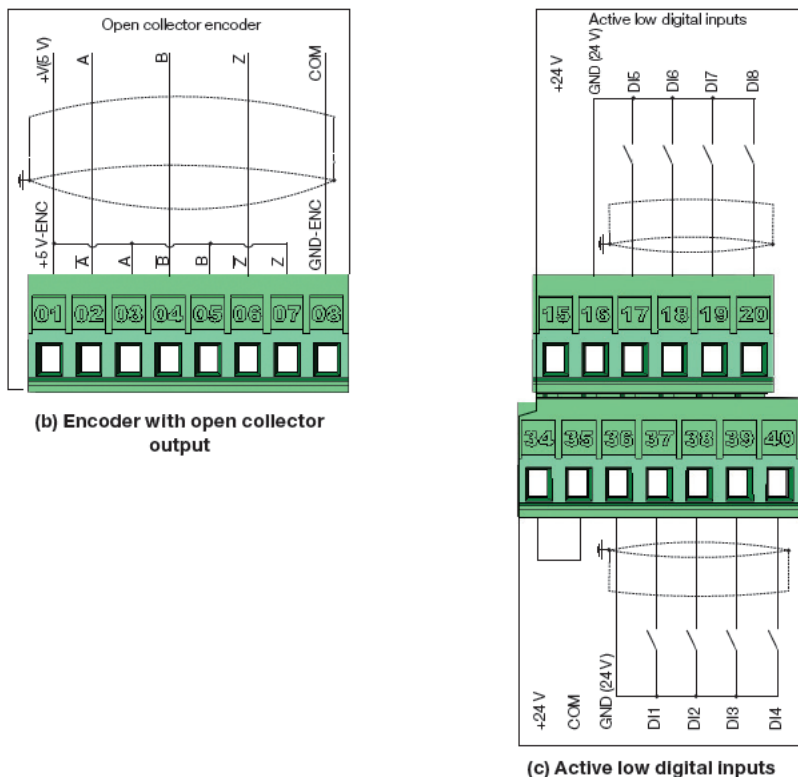
The CFW700 inverters are supplied with the digital inputs configured as active high and the analog inputs and outputs configured for voltage signal 0...10 V.

NOTE!

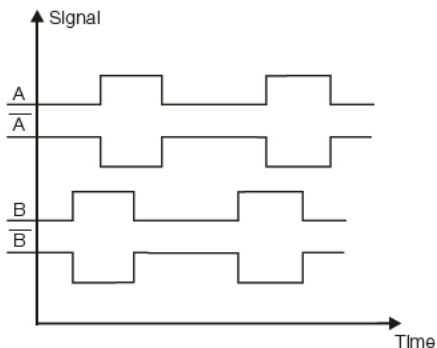
To be able to use the analog input and/or output as current signals, it is necessary to change the switch S1 and the related parameters as per [Table 3.1 on page 22](#). In order to set the analog inputs to bipolar voltage signal (-10...10 V), it is necessary to set P0233 and P0238 according to [Table 3.1 on page 22](#). Refer to the CFW700 programming manual for more information.

Table 3.1: Configuration of the switch for the analog input and output signals selection

Input/Output	Signal	S1 Switch Settings	Signal Range	Parameter Settings
AI1	Voltage	S1.2 = OFF (*)	0...10 V (*)	P0233 = 0 (direct reference) or 2 (reverse reference).
			-10...10 V	P0233 = 4
AI2	Current	S1.2 = ON	0...20 mA	P0233 = 0 (direct reference) or 2 (reverse reference).
			4...20 mA	P0233 = 1 (direct reference) or 3 (reverse reference).
AI2	Voltage	S1.1 = OFF (*)	0...10 V (*)	P0238 = 0 (direct reference) or 2 (reverse reference).
			-10...10 V	P0238 = 4
AO1	Current	S1.1 = ON	0...20 mA	P0238 = 0 (direct reference) or 2 (reverse reference).
			4...20 mA	P0238 = 1 (direct reference) or 3 (reverse reference).
AO1	Voltage	S1.3 = ON (*)	0...10 V (*)	P0253 = 0 (direct reference) or 2 (reverse reference).
			0...20 mA	P0253 = 0 (direct reference) or 2 (reverse reference).
AO2	Current	S1.3 = OFF	4...20 mA	P0253 = 1 (direct reference) or 3 (reverse reference).
			0...10 V (*)	P0256 = 0 (direct reference) or 2 (reverse reference).
AO2	Voltage	S1.4 = ON (*)	0...10 V (*)	P0256 = 0 (direct reference) or 2 (reverse reference).
			0...20 mA	P0256 = 0 (direct reference) or 2 (reverse reference).
AO2	Current	S1.4 = OFF	4...20 mA	P0256 = 1 (direct reference) or 3 (reverse reference).

(*) Factory setting.

NOTE!

Settings of the S2 switch:

- S2.1 = ON and S2.2 = ON: RS-485 is ON.
- S2.1 = OFF and S2.2 = OFF: RS-485 is OFF.

The factory default for the S2.1 and S2.2 switches are OFF.

Other combinations of switch S2 are not allowed.

Technical specifications for the encoder and the encoder cable as shown in [Table 3.2 on page 23](#).

Table 3.2: Technical specifications for the encoder and the encoder cable

	Characteristics	Specifications
Encoder	Power supply	5 V
	Channels	2 channels In quadrature (90°) + zero pulses with complementary outputs (differentials) or open-collector.
	Signals	A, \bar{A} , B, \bar{B} , Z and \bar{Z} Available for 2 channels: A, \bar{A} , B, \bar{B} . If the channel zls not used, leave the terminals XC1: 6 and 7 not connected. Noother setting are necessary.
	Output circuit	Linedrive type, push-pull or open-collector. Maximum voltage of 12 V.
	Isolation	Electronic circuit Isolated from the encoder frame.
	Pulses	Recommended number of pulses per rotation = 1024 ppr.
	Frequency	Maximum allowed = 100 kHz.
Encoder cable	Type of cable	Balanced cable shield (for differential signals operation).
	Connection	The cable shield must be connected to ground through devices on control shield plate (see Figure 3.5 on page 21).
	Distance	≥ 25 cm of other wiring.
	Isolation	Use metal conduit.
	Length	Maximum = 10 m.

Follow instructions below for the proper installation of the control wiring:

1. Wire gauge: 0.5 mm² (20 AWG) to 1.5 mm² (14 AWG).
2. Maximum tightening torque: 0.50 N.m (4.50 lbf.in).
3. Use shielded cables for the connections in XC1 and run the cables separated from the remaining circuits (power, 110 V / 220 Vac control, etc.), according to [Item 3.2.6 Cable Distances on page 24](#). If control wiring must cross other cables (power cables for instance), make it cross perpendicular to the wiring and provide a minimum separation of 5 cm (1.9 in) at the crossing point.

Refer to [Item 3.2.6 Cable Distances on page 24](#), for the proper cable distances.

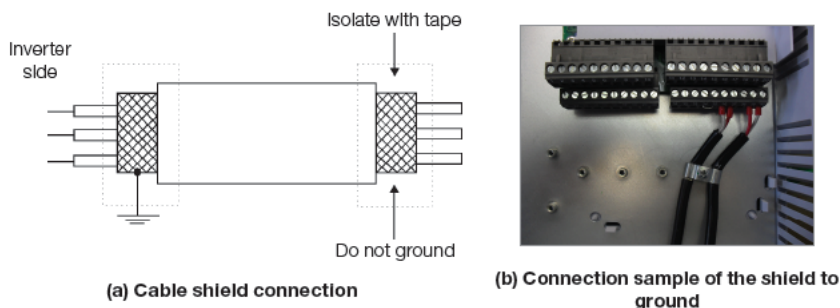

Figure 3.7: (a) and (b) Shield connection

4. Relays, contactors, solenoids or coils of electromechanical brakes installed close to the inverter may eventually create interferences in the control circuitry. To eliminate this effect, RC suppressors (with AC power supply) or free-wheel diodes (with DC power supply) shall be connected in parallel to the coils of these devices.

3.2.6 Cable Distances

The power cables and control cables must be separated (relay output cables and other control cables) according to [Table 3.3 on page 24](#).

Table 3.3: Cable distances

Rated Output Inverter Current	Cable Length(s)	Minimum Separation Distance
≤ 24 A	≤ 100 m (330 ft)	≥ 10 cm (3.94 in)
	> 100 m (330 ft)	≥ 25 cm (9.84 in)
≥ 28 A	≤ 30 m (100 ft)	≥ 10 cm (3.94 in)
	> 30 m (100 ft)	≥ 25 cm (9.84 in)

3.3 INSTALLATION ACCORDING TO THE EUROPEAN DIRECTIVE OF ELECTROMAGNETIC COMPATIBILITY

The inverters with C3 option (CFW700...C3...) have internal C3 RFI filter to reduce electromagnetic interference. These inverters, when properly installed, meet the requirements of the directive of electromagnetic compatibility (2014/30/EU).

The CFW700 inverter series has been designed only for industrial applications. Therefore, the emission limits of harmonic currents defined by the standards EN 61000-3-2 and EN 61000-3-2/A 14 are not applicable.

3.3.1 Conformal Installation

1. Inverters with built-in C3 RFI filter CFW700...C3...
2. Frame sizes A to D inverters with built-in C3 RFI filter capacitors grounding screws and frame size E with J1 cable in the  position (XE1). For more information see [Figure A.8 on page 214](#).
3. Shielded output cables (motor cables) and connect the shield at both ends (motor and inverter) with a low impedance connection for high frequency. Use PCSx-01 kit supplied with frame sizes A, B and C inverters. For frame sizes B and C with degree of protection IP55, use the PCSC-03 shield kit. For frame sizes D and E inverters use the clamps supplied with the product. Ensure good contact between the cable shield and the clamps. Refer to [Figure 3.4 on page 19](#) and keep the proper separation from other cables according to [Item 3.2.6 Cable Distances on page 24](#). The maximum motor cable length and conduction and radiated emission levels are presented at [Table B.7 on page 234](#). Use an external RFI filter at the input of the inverter if necessary to have a lower emission level and/or a longer motor cable length. For more information (RFI filter commercial reference, motor cable length and emission levels) refer to [Table B.7 on page 234](#).
4. Shielded control cables and separate the remaining cables according to [Item 3.2.6 Cable Distances on page 24](#).
5. Inverter grounding according to the instructions on [Item 3.2.4 Grounding Connections on page 19](#).
6. Grounded power supply.

3.3.2 Emission and Immunity Levels

Table 3.4: Emission and immunity levels

EMC Phenomenon	Basic Standard	Level
Emission:		
Mains Terminal Disturbance Voltage Frequency Range: 150 kHz to 30 MHz)	IEC/EN61800-3	It depends on the inverter model and the motor cable length. See Table B.7 on page 234 .
Electromagnetic Radiation Disturbance Frequency Range: 30 MHz to 1000 MHz)		
Immunity:		
Electrostatic Discharge (ESD)	IEC 61000-4-2	4 kV for contact discharge and 8 kV for air discharge.
Fast Transient-Burst	IEC 61000-4-4	2 kV / 5 kHz (coupling capacitor) power input cables; 1 kV / 5 kHz control cables, and remote keypad cables; 2 kV / 5 kHz (coupling capacitor) motor output cables.
Conducted Radio-Frequency Common Mode	IEC 61000-4-6	0.15 to 80 MHz; 10 V; 80 % AM (1 kHz). Power supply cable, motor, control and remote keypad (HMI).
Surge Immunity	IEC 61000-4-5	1.2/50 μ s, 8/20 μ s; 1 kV line-to-line coupling; 2 kV line-to-ground coupling.
Radio-Frequency Electromagnetic Field	IEC 61000-4-3	80 to 1000 MHz; 10 V/m; 80 % AM (1 kHz).

Refer to [Table B.7 on page 234](#) for conducted and radiated emission levels accomplished with and without external RFI filter. The reference model for the external filter is also presented.

4 KEYPAD (HMI) AND BASIC PROGRAMMING

4.1 INTEGRAL KEYPAD - HMI-CFW700

The integral keypad can be used to operate and program (view / edit all parameters) of the CFW700 inverter. There are two operation modes in the keypad: monitoring and programming. The key functions and display indications of the keypad may change according to the operation mode. The programming mode consists of three levels.

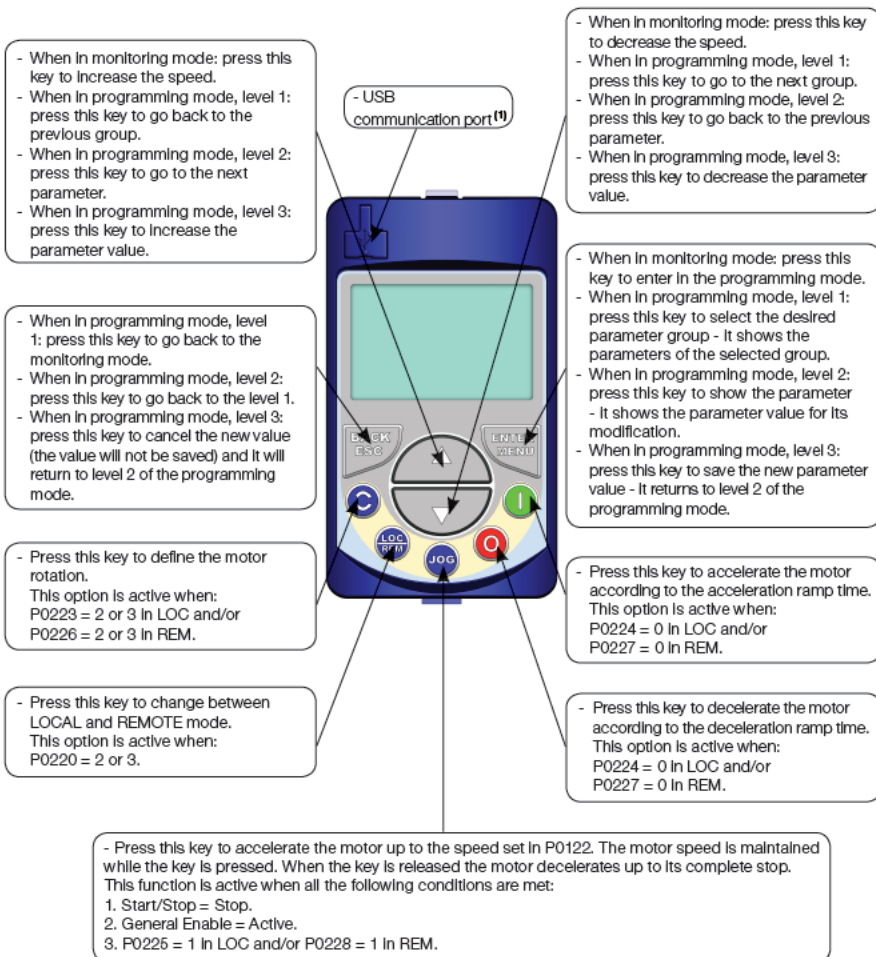

(1) Available from the serial number 1024003697.

Figure 4.1: Operator keys

NOTE!

It is necessary to set the password at P0000 for parameter modification. Otherwise the parameters contents can only be viewed. The default password for P0000 is 5. It is possible to change the password at P0200. Refer to the CFW700 programming manual.

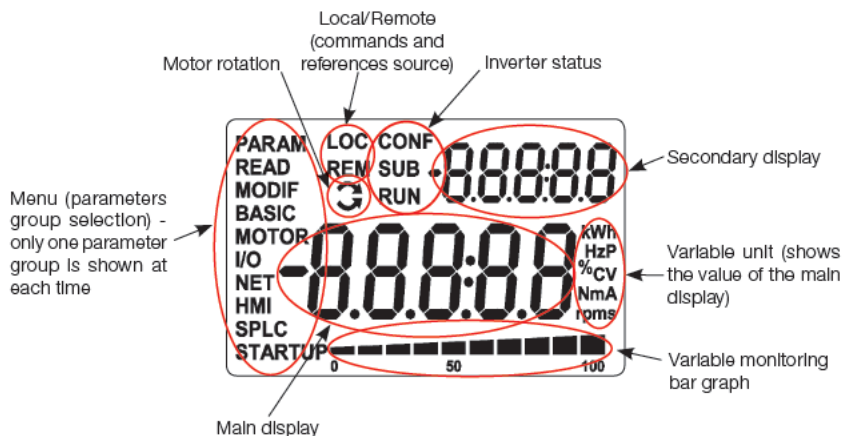

Figure 4.2: Display sections

Parameter groups available at the Menu:

- **PARAM:** all parameters.
- **READ:** only the reading parameters.
- **MODIF:** only the parameters changed compared to the factory default.
- **BASIC:** basic application parameters.
- **MOTOR:** parameters related to motor data control.
- **I/O:** parameters related to the digital and analog inputs/outputs.
- **NET:** parameters related to the communication protocol.
- **HMI:** parameters for the keypad configuration.
- **SPLC:** parameters related to the SoftPLC function.
- **STARTUP:** parameters for the Oriented Start-up.

Inverter status:

- **LOC:** local reference.
- **REM:** remote reference.
- : motor rotation according to the arrows.
- **CONF:** configuration. It indicates that the inverter is in the Oriented Start-up routine or with incompatible parameter programming. Refer section Incompatibility Between Parameters in the programming manual of the CFW700.
- **SUB:** DC link undervoltage.
- **RUN:** inverter enabled and/or DC braking activated.

Monitoring Mode	
	<ul style="list-style-type: none"> ■ It is the initial state of the keypad after power up and startup screen, with the factory default values. ■ The Menu is not active in this mode. ■ Main display, secondary display and monitoring bar show the values of the parameters defined at P0205, P0206 and P0207. ■ From the monitoring mode, pressing the ENTER/MENU key will switch to the programming mode.
Programming Mode	
	<p>Level 1:</p> <ul style="list-style-type: none"> ■ This is the first level of the programming mode. It is possible to choose the parameter group by using the and keys. ■ The main display, secondary display and monitoring bar are not shown at this level. ■ Press the ENTER/MENU key to go to the second level of programming mode - parameters selection. ■ Press the BACK/ESC key to go back to the monitoring mode.
	<p>Level 2:</p> <ul style="list-style-type: none"> ■ The parameter number is displayed on the main display and its value on the secondary display. ■ Use the and keys to find the desired parameter. ■ Press the ENTER/MENU key to go to level 3 of the programming mode - parameters value changing. ■ Press the BACK/ESC key to return to level 1 of the programming mode.
	<p>Level 3:</p> <ul style="list-style-type: none"> ■ The parameter values is shown at the main display and the parameter number at the secondary display. ■ Use the and keys to change the value of the selected parameter. ■ Press ENTER/MENU key to confirm the modification (save the new value) or BACK/ESC key to cancel the modification (do not save the new value). In both cases, the keypad returns to the second level of the programming mode.

Figure 4.3: Keypad operation modes

The keypad can be installed or removed from the inverter with or without AC power applied to the inverter.

The HMI supplied with the product can also be used for remote command of the inverter. In this case, use a cable with male and female D-Sub9 (DB-9) connectors wired pin to pin (mouse extension type) or a market standard Null-Modem cable. Maximum length of 50 m (164 ft). It is recommended the use of the M3 x 5.8 standoffs supplied with the product. Recommended torque: 0.5 N.m (4.5 lbf.in).

Use the keypad frame accessory to assembly the keypad on the panel door or control table (see [Section 7.2 ACCESSORIES on page 60](#), or perform the drilling as shown in [Figure A.5 on page 211](#)).

**NOTE!**

A list of parameters is supplied with the product, for additional information on each parameter refer to the CFW700 programming manual available for download on website: www.weg.net.

4.2 APPLICATIONS

The CFW700 has some features that allow better matching the inverter commands to the application. These features were grouped into a set of applications and can be as simple as the forward and reverse command, or more elaborated such as a PID controller. The applications were implemented using the SoftPLC function, in other words, ladder programming applicative built-in to the CFW700 inverter. It allows the user that has the WLP and the built-in implemented applicative to change it and use it as an user applicative.

Parameter P1003 allows selecting an application and uploading it to the CFW700. The CFW700 has following applications built-in:

- PID Regulator.
- Electronic Potentiometer (E.P.).
- Multispeed.
- 3-Wire Start/Stop.
- Forward/Reverse Run.

4.2.1 PID Regulator Application

The CFW700 has the PID REGULATOR application that can be used to control a closed loop process. This application sets proportional, integral and derivative regulator superimposed to the regular speed control of the CFW700 inverter.

The CFW700 will compare the setpoint with the process variable and control the motor speed trying to eliminate any error and keeping the process variable equal to the setpoint. The setting of the P, I and D gains determines how fast the inverter will respond to eliminate this error.

Application examples:

- Flow control or pressure in a pipe system.
- Temperature of a furnace or oven.
- Dosing of chemicals in tanks.

The following example defines the terms used by the PID controller.

A pump used in a water pumping system where is necessary to control the pressure of the pipe. A pressure transducer is installed in the pipe and supplies an analog feedback signal to the CFW700, which is proportional to the water pressure. This signal is called the process variable, and can be visualized at the parameter P1012. A setpoint is programmed in the CFW700 via keypad (P1025), through an analog input (such as a 0-10 V or 4-20 mA signal) or via communication network. The setpoint is the desired water pressure value that the pump is supposed to produce, regardless of the consumption variations at the pump output at any time.

It is necessary to set the parameter P0221 or P0222 to 7 = SoftPLC for the operation of the PID Regulator application.

Definitions:

- The Function 1 of the Application at parameters P0231 or P0236 represents the value of the PID Setpoint.
- The Function 2 of the Application at parameters P0231 or P0236 represents the value of the PID Feedback.
- The Function 1 of the Application at parameters P0251 or P0254 represents the value of the PID Setpoint.
- The Function 2 of the Application at parameters P0251 or P0254 represents the value of the PID Feedback.
- The Function 1 of the Application at parameters P0263 or P0270 represents the value of the Manual/Auto command.
- The Function 1 of the Application at parameters P0275 to P0279 represents the VP>VPx logical condition.
- The Function 2 of the Application at parameters P0275 to P0279 represents the VP<VPy logical condition.

The PID setpoint can receive an analog input signal (AI1 or AI2). It is necessary to set P1016 to 1 = AIx and select which analog input will be used. The analog inputs are set at P0231 (AI1) or P0236 (AI2) and it is necessary to program it to 5 = Function 1 of the Application in order to enable the analog inputs for the operation. The following alarm message will be displayed in case it is not properly done: "A770: Set AI1 or AI2 for Function 1 of the Application".

The PID setpoint value can be presented via analog output AO1 or AO2. It is necessary to set P0251 (AO1) or P0254 (AO2) to 17 = Function 1 of the Application. The full scale value of the variable is 100.0 % and corresponds to 10 V or 20 mA.

The PID feedback can receive an analog input signal (AI1 or AI2). It is necessary to set P0231 (AI1) or P0236 (AI2) to 6 = Function 2 of the Application in order to enable the analog inputs for the operation. The following alarm message will be displayed in case it is not properly done: "A772: Set AI1 or AI2 for Function 2 of the Application".

In case the analog inputs (AI1 and AI2) are programmed with the same function, PID Setpoint or Feedback, the following alarm message will be displayed and the application will not be enabled: "A774: AI1 and AI2 were set for the same function".

The value of the PID feedback can be presented via analog output AO1 or AO2. It is necessary to set P0251 (AO1) or P0254 (AO2) to 18 = Function 2 of the Application. The full scale value of the variable is 100.0 % and corresponds to 10 V or 20 mA.

The Manual/Auto control is done by a digital input (DI1 to DI8). It is necessary to set one of the DI parameters (P0263 to P0270) to 20 = Function 1 of the Application. If more than one digital input is set for this function, the logic operation will consider only the command of the high priority level digital input, where: DI1>DI2>DI3>DI4>DI5>DI6>DI7> DI8. If any of the digital inputs is set, the PID controller will work only in automatic (Auto) mode.

The Manual/Auto input is active when it is in 24 V indicating automatic control and it is inactive in 0 V indicating manual operation.

The digital outputs (DO1 to DO5) can be programmed to trigger comparison logics with the process variable (PV). In order to do that, it is necessary to set one of the DO's parameters (P0275 to P0279) to 34 = Function 1 of the Application (VP>VPx) or 35 = Function 2 of the Application (VP<VPy).

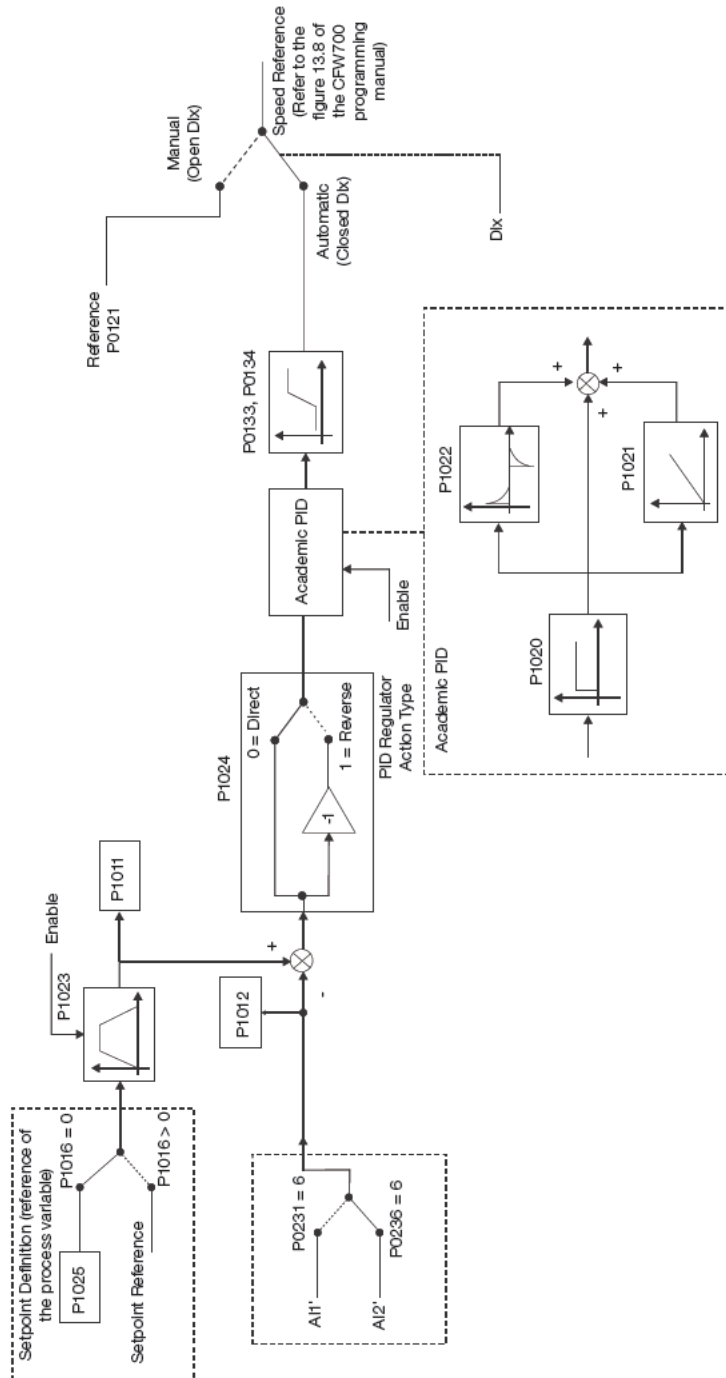

Figure 4.4: PID Regulator block diagram

4.2.1.1 Academic PID

The PID controller implemented in CFW700 is the academic type. The equations that characterize the Academic PID, which is the base of this function algorithm, are presented next. The transfer function in the Academic PID regulator frequency domain is:

$$y(s) = K_p \times e(s) \times \left[1 + \frac{1}{sT_i} + sT_d \right]$$

By replacing the integrator by a sum and the derivative by the incremental quotient, one gets an approximation for the discrete transfer equation (recursive) presented next:

$$y(k) = y(k-1) + K_p \left[(1 + K_i T_a + K_d / T_a) e(k) - (K_d / T_a) e(k-1) \right]$$

Being:

y(k): current PID output, can vary from 0.0 to 100.0 %;

y(k-1): PID previous output;

K_p (Proportional gain): $K_p = P1020$;

K_i (Integral gain): $K_i = P1021 \times 100 = [1/T_i \times 100]$;

K_d (Differential gain): $K_d = P1022 \times 100 = [T_d \times 100]$;

T_a = 0.05sec (PID regulator sampling time);

e(k): current error $[SP^*(k) - X(k)]$;

e(k-1): previous error $[SP^*(k-1) - X(k-1)]$;

SP*: reference, can vary from 0.0 to 100.0 %;

X: process variable (or feedback), read through one of the analog inputs (Alx), can vary from 0.0 to 100.0 %.

The parameters related to this application are:

P1010 - Version of the PID Regulator Application

Adjustable Range:	0.00 to 10.00	Factory Setting:
Properties:	ro	
Access Groups via HMI:	<input type="text" value="SPLC"/>	

Description:

Read only parameter that presents the software version of the PID Controller application developed for the SoftPLC function of the CFW700.

P1011 - Current Control Setpoint of the PID

Adjustable Range:	0.0 to 3000.0	Factory Setting:
Properties:	ro	
Access Groups via HMI:	<input type="text" value="SPLC"/>	

Description:

Read only parameter that presents, in the wxy.z form without engineering unit, the setpoint value of the PID Controller according to the scale defined at P1018.

P1012 - PID Process Variable

Adjustable Range:	0.0 to 3000.0	Factory Setting: -
Properties:	ro	
Access Groups via HMI:	<input type="text" value="SPLC"/>	

Description:

Read only parameter that presents, in the wxy.z form without engineering unit, the value of the process variable of the PID Controller according to the scale defined at P1018.

P1013 - PID Controller Output

Adjustable Range:	0.0 to 100.0 %	Factory Setting: -
Properties:	ro	
Access Groups via HMI:	<input type="text" value="SPLC"/>	

Description:

Read only parameter that presents, in percentage (%), the PID Controller output value.

P1016 - PID Controller Setpoint Selection

Adjustable Range:	0 = HMI 1 = AIx 2 = Serial/USB 3 = CO/DN/DP	Factory Setting: 0
Properties:	ro	
Access Groups via HMI:	<input type="text" value="SPLC"/>	

Description:

It defines the origin source of the control setpoint of the PID Controller.

Notes:

- "HMI" means that the control setpoint of the PID Controller will be the the value of of P1025 parameter.
- "AI" means that the control setpoint of the PID Controller will come from an analog input. It is necessary to set P0231 (AI1) or P0236 (AI2) to 5 = Function 1 of the Application in order to enable its operation. The following alarm message will be displayed in case it is not properly done: "A0770: Set AI1 or AI2 for Function 1 of the Application".
- "Serial/USB" means that the control setpoint of the PID Controller will be the value of P0683 proportionally referenced to the percentage value with one decimal point, i.e., 100.0 % corresponds to 1000 in P0683.

- “CO/DN/DP” means that the setpoint of the PID Controller will be the value of P0685 proportionally referenced to the percentage value with one decimal point, i.e., 100.0 % corresponds to 1000 in P0685.

P1018 - PID Feedback Scale

Adjustable Range:	0.0 to 3000.0	Factory Setting:	100.0
Properties:	-		
Access Groups via HMI:	<input type="text" value="SPLC"/>		

Description:

Defines how the PID Feedback or Process Variable will be presented in P1012 (as well as the PID setpoint in P1011), i.e., the full scale of the process variable of the PID Controller that corresponds to 100.0 % in the analog input used as process variable of the PID Controller.

The variable will always be with one decimal point “wxy.z”, i.e., one place after the dot.

Example: The pressure transducer is a 4-20 mA with 0-25 bar range. Set P1018 to 25.0.

P1020 - PID Proportional Gain

P1021 - PID Integral Gain

P1022 - PID Differential Gain

Adjustable Range:	0.000 to 30.000	Factory Setting:	P1020 = 1.000 P1021 = 0.430 P1022 = 0.000
Properties:	-		
Access Groups via HMI:	<input type="text" value="SPLC"/>		

Description:

These parameters define the PID Controller application gains and they should be set according to the application being controlled.

Examples of initial settings for some applications are presented in [Table 4.1 on page 36](#).

Table 4.1: Recommended settings for the PID controller gains

Variable	Gains		
	Proportional P1020	Integral P1021	Derivative P1022
Pneumatic system pressure	1	0.430	0.000
Pneumatic system flow	1	0.370	0.000
Hydraulic system pressure	1	0.430	0.000
Hydraulic system flow	1	0.370	0.000
Temperature	2	0.040	0.000
Level	1	See note below	0.000

NOTE!

For the level control, the integral gain settings will depend on the time it takes for the reservoir to go through the minimum acceptable level to the desired level, with the following conditions:

1. The time for the direct action should be measured with the maximum input flow and minimum output flow.
2. The time for the reverse action should be measured with minimum input flow and maximum output flow.

An equation to calculate the initial value of P1021 as a function of the system response time is presented next:

$$P1021 = 5.00 / t,$$

Where: t = time (in seconds)

P1023 - Filter for the Control Setpoint of the PID

Adjustable Range:	0.00 to 650.00 s	Factory Setting:	0.25 s
Properties:	-		
Access Groups via HMI:	<input style="width: 150px;" type="text" value="SPLC"/>		

Description:

This parameter sets the value of the constant time of the setpoint filter of the PID regulator and has the purpose of reducing abrupt changes in the PID setpoint value.

P1024 - PID Regulator Action Type

Adjustable Range:	0 = Direct 1 = Reverse	Factory Setting:	0
Properties:	-		
Access Groups via HMI:	<input style="width: 150px;" type="text" value="SPLC"/>		

Description:

The PID Controller action type should be selected as "Direct" when it is necessary that the motor speed is increased in order to increment the process variable. Otherwise, the "Reverse" should be selected.

Table 4.2: Selecting the PID action type

Motor Speed	Process Variable	Selection
Increases	Increases	Direct
	Decreases	Reverse

This characteristic varies with the process type, but direct feedback is most used.

For temperature control or level process, the selection of the action type will depend on the configuration.

Example: if the inverter runs the motor that removes fluid from the reservoir in a control level, the action type is reverse as the inverter should increase the motor speed in order to decrease the level of fluid. In case the inverter is running the motor that is adding fluid in the reservoir, the action type is direct.

P1025 - PID Setpoint via Keypad Keys (HMI)

Adjustable Range:	0.0 to 100.0 %	Factory Setting:	0.0 %
Properties:	-		
Access Groups via HMI:	<input type="text" value="SPLC"/>		

Description:

This parameter allows the adjustment of the control setpoint of the PID Controller through the keypad keys, since P1016 = 0 and it is operating in Auto mode. If the operation is in Manual mode, the keypad reference is set in P0121.

The value of P1025 is kept with the last value set (backup) even after disabling or resetting the inverter (with P1027 = 1 - Active).

P1026 - Automatic Setting of the PID Setpoint via Keypad (P1025)

Adjustable Range:	0 = Inactive 1 = Active	Factory Setting:	1
Properties:	cfg		
Access Groups via HMI:	<input type="text" value="SPLC"/>		

Description:

When the control setpoint of the PID Controller is done via the keypad (P1016 = 0) and P1026 is 1 (active), when switching from manual to automatic, the percentage value of the manual setpoint that corresponds to the PID Controller output from 0.0 to 100.0 % will be loaded at P1025. It avoids PID oscillations when switching from manual to automatic.

P1027 - PID Setpoint Backup via Keypad (P1025)

Adjustable Range:	0 = Inactive 1 = Active	Factory Setting:	1
Properties:	-		
Access Groups via HMI:	<input type="text" value="SPLC"/>		

Description:

This parameter sets whether the backup function of the control setpoint of the PID Controller via keypad is active or inactive.

If P1027 = 0 (Inactive), the inverter will not save the value of the control setpoint of the PID Controller when disabled. Therefore, when the inverter is enabled again, the value of the control setpoint of the PID Controller is 0.0 %.

P1028 - PID Output N = 0

Adjustable Range:	0.0 to 100.0 %	Factory Setting:	0.0 %
Properties:	-		
Access Groups via HMI:	<input type="text" value="SPLC"/>		

Description:

The P1028 parameter works together with the P0218 parameter (Condition to Leave the Zero Speed Disable), providing additional requirement for leaving the condition. Thus, it is necessary that the error of the PID controller (the difference between the control setpoint and process variable) is greater than the value programmed in P1028 for the inverter to operate the motor again, this state is known as “wake up”.

P1031 - X Process Variable Value
P1032 - Y Process Variable Value

Adjustable Range:	0.0 to 100.0 %	Factory Setting:	P1031 = 90.0 % P1032 = 10.0 %
Properties:	-		
Access Groups via HMI:	<input type="text" value="SPLC"/>		

Description:

These parameters are used at the digital outputs functions for signaling/alarm, and will show: Process Variable > VPx (Function 1 of the Application) and Process Variable < VPy (Function 2 of the Application).

4.2.2 Electronic Potentiometer Application (E.P.)

The CFW700 has the Electronic Potentiometer (E.P.) function that allows the speed reference to be adjusted via two digital inputs, one for accelerating and another for decelerating the motor.

With the inverter enabled and the Dlx digital input set to “Function 1 of the Application (Accelerate)” activated, the motor is accelerated according to the programmed acceleration ramp up to the maximum speed. If only the Dlx digital input set to “Function 2 of the Application (Decelerate)” is active and the inverter is enabled, the motor speed is decreased according to the programmed deceleration ramp up to minimum speed. If both inputs are active, the motor will decelerate for safety reasons. With the inverter disabled, Dlx digital inputs are ignored unless both are active, which the speed reference is set to 0 rpm. The following figure illustrates this condition.

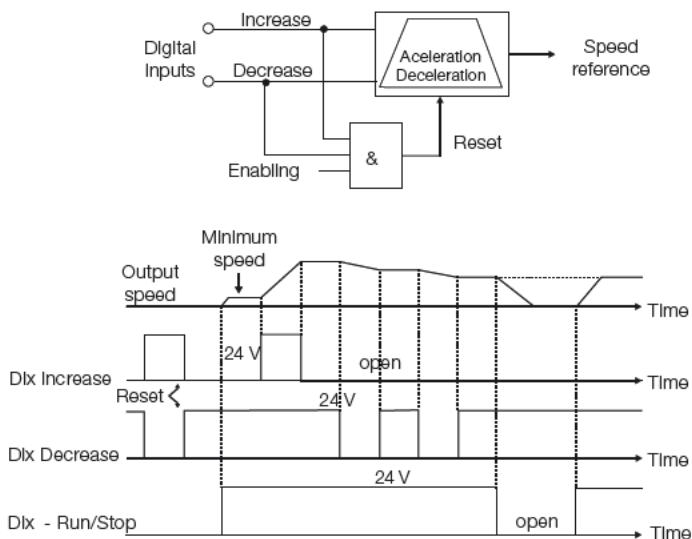

Figure 4.5: Operation of the Electronic Potentiometer application (E.P.)

It is necessary to set P0221 or P0222 to 7 = SoftPLC for the operation of the electronic potentiometer application.

Definitions:

- The Function 1 of the Application at P0263 to P0270 represents the Accelerate command.
- The Function 2 of the Application at P0263 to P0270 represents the Decelerate command.

The accelerate command is done by one of the digital inputs (DI1 to DI8). It is necessary to set one of the DI's parameters (P0263 to P0270) to 20 = Function 1 of the Application.

If more than one digital input is set for this function, the logic operation will consider only the command of the high priority level digital input, where: DI1>DI2>DI3>DI4>DI5>DI6>DI7>DI8. If any of the digital inputs is set, the following alarm message will be displayed: “A0750: Set a DI for Function 1 of the Application (Accelerate)” and the operation of the application will not be enabled.

The decelerate command is also done by one of digital inputs (DI1 to DI8). However, it is necessary to set one the DI's parameters (P0263 to P0270) to 21 = Function 2 of the Application. If more than one digital input is set for this function, the logic operation will consider only the command of the high priority level digital input, where: DI1>DI2>DI3>DI4>DI5>DI6>DI7>DI8. If any of the digital inputs is set, the following alarm message will be displayed: "A0752: Set a DI for Function 2 of the Application (Decelerate)" and the operation of the application will not be enabled.

The Accelerate input is active when 24 V is applied and inactive when 0 V is applied. Otherwise, the Decelerate input is active when 0 V is applied and inactive when 24 V is applied.

Parameter P1011 shows the current value of the speed reference in rpm and it helps to keep the speed reference value when there is no accelerate or decelerate command.

Parameter P1012 sets if the speed reference backup is enabled or if it will go to 0 rpm in a new inverter enabling.

NOTE!

In case the Electronic Potentiometer application was selected to operate in local mode and DI1 (P0263) is selected for the accelerate or decelerate command, the inverter may go to the "configuration (CONF)" status; then it is necessary to change the default programming of parameter P0227.

P1010 - Version of the Electronic Potentiometer Application (E.P.)

Adjustable Range:	0.00 to 10.00	Factory Setting: -
Properties:	ro	
Access Groups via HMI:	<input type="text" value="SPLC"/>	

Description:

Read only parameter that presents the software version of the electronic potentiometer application developed for the SoftPLC function of the CFW700.

P1011 - E.P. Speed Reference

Adjustable Range:	0 to 18000 rpm	Factory Setting: -
Properties:	ro	
Access Groups via HMI:	<input type="text" value="SPLC"/>	

Description:

Read only parameter that presents, in rpm, the current speed reference value of the electronic potentiometer application.

P1012 - E.P. Speed Reference Backup

Adjustable Range:	0 = Off 1 = On	Factory Setting: 1
Properties:	-	
Access Groups via HMI:	SPLC	

Description:

This parameter sets whether the backup function of the electronic potentiometer speed reference is active or inactive.

If P1012 = 0 (Inactive), the inverter will not save the value of the speed reference when disabled. Therefore, when the inverter is enabled again, the speed reference value will be the minimum speed set in P0133.

4.2.3 Multispeed Application

The CFW700 has the Multispeed application that allows the speed reference to be set by the values defined at parameters P1011 to P1018 through the logical combination of digital inputs DI4, DI5 and DI6, having the limit of eight pre-programmed speed references. It brings advantages such as stability of the pre-programmed fixed references and electrical noise immunity (isolated digital inputs DIx).

The speed reference selection is done by the logical combination of the digital inputs DI4, DI5 and DI6. Their respective parameters (P0266, P0267 and P0268) must be set to "Function 1 of the Application (Multispeed)". If any digital input is set to "Function 1 of the Application", the following alarm message will be displayed "A0750: Set a DI for Multispeed" and the speed reference of the inverter will not be enabled.

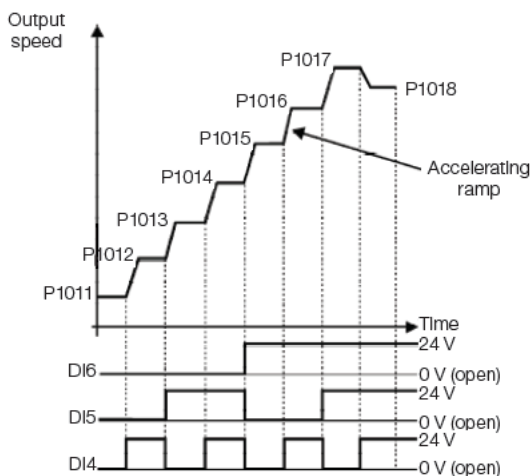

Figure 4.6: Operation of the Multispeed Application

For the operation of the multispeed application, it is necessary to set the parameter P0221 or P0222 to 7 = SoftPLC.

Definition:

- The Function 1 of the Application in the parameters P0266 to P0268 represents the Multispeed command.

The speed reference selection works according to the table below:

Table 4.3: Multispeed Reference

D16	D15	D14	Speed Reference
0 V	0 V	0 V	P1011
0 V	0 V	24 V	P1012
0 V	24 V	0 V	P1013
0 V	24 V	24 V	P1014
24 V	0 V	0 V	P1015
24 V	0 V	24 V	P1016
24 V	24 V	0 V	P1017
24 V	24 V	24 V	P1018

If any digital input is selected for Multispeed, it should be considered as 0 V.

The parameters P1011 to P1018 define the speed reference value when the Multispeed is operating.

P1010 - Version of the Multispeed Application

Adjustable Range:	0.00 to 10.00	Factory Setting:	-
Properties:	ro		
Access Groups via HMI:	<input type="text" value="SPLC"/>		

Description:

Read only parameter that presents the software version of the Multispeed application developed for the SoftPLC function of the CFW700.

P1011 - Multispeed Reference 1

Adjustable Range:	0 to 18000 rpm	Factory Setting:	90 rpm
Properties:	ro		
Access Groups via HMI:	<input type="text" value="SPLC"/>		

Description:

Sets the speed reference 1 for the Multispeed application.

P1012 - Multispeed Reference 2

Adjustable Range:	0 to 18000 rpm	Factory Setting:	300 rpm
Properties:	-		
Access Groups via HMI:	<input type="text" value="SPLC"/>		

Description:

Sets the speed reference 2 for the Multispeed application.

P1013 - Multispeed Reference 3

Adjustable Range:	0 to 18000 rpm	Factory Setting:	600 rpm
Properties:	-		
Access Groups via HMI:	<input type="text" value="SPLC"/>		

Description:

Sets the speed reference 3 for the Multispeed application.

P1014 - Multispeed Reference 4

Adjustable Range:	0 to 18000 rpm	Factory Setting:	900 rpm
Properties:	-		
Access Groups via HMI:	<input type="text" value="SPLC"/>		

Description:

Sets the speed reference 4 for the Multispeed application.

P1015 - Multispeed Reference 5

Adjustable Range:	0 to 18000 rpm	Factory Setting:	1200 rpm
Properties:	-		
Access Groups via HMI:	<input type="text" value="SPLC"/>		

Description:

Sets the speed reference 5 for the Multispeed application.

P1016 - Multispeed Reference 6

Adjustable Range:	0 to 18000 rpm	Factory Setting:	1500 rpm
Properties:	-		
Access Groups via HMI:	<input type="text" value="SPLC"/>		

Description:

Sets the speed reference 6 for the Multispeed application.

P1017 - Multispeed Reference 7

Adjustable Range:	0 to 18000 rpm	Factory Setting:	1800 rpm
Properties:	-		
Access Groups via HMI:	<input type="text" value="SPLC"/>		

Description:

Sets the speed reference 7 for the Multispeed application.

P1018 - Multispeed Reference 8

Adjustable Range:	0 to 18000 rpm	Factory Setting:	1650 rpm
Properties:	-		
Access Groups via HMI:	<input type="text" value="SPLC"/>		

Description:

Sets the speed reference 8 for the Multispeed application.

4.2.4 3-Wire Start/Stop Command Application

The CFW700 has the 3-Wire Start/Stop application that allows the inverter Start/Stop command to be performed as a direct online start with emergency button and retention contact.

This way, the digital input (Dlx) programmed to "Function 1 of the Application (Start)" will be able to enable the inverter with a single pulse in case the Dlx set to "Function 2 of the Application (Stop)" is active. The inverter disables the ramp when the digital input Stop is inactive. The picture below show how it works.

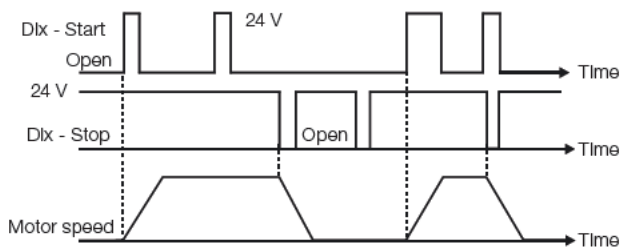

Figure 4.7: Operation of the 3-Wire Start/Stop Application

It is necessary to set the parameter P0224 or P0227 to 4 = SoftPLC for the operation of the 3-Wire Start/Stop application.

Definitions:

- The Function 1 of the Application at parameters P0263 to P0270 represents the Start command.
- The Function 2 of the Application at parameters P0263 to P0270 represents the Stop command.

The Start command is done by one of the digital inputs (DI1 to DI8). It is necessary to set one of the DI's parameters (P0263 to P0270) to 20 = Function 1 of the Application. If more than one digital input is set for this function, the logic operation will consider only the command of the high priority level digital input, where: DI1>DI2>DI3>DI4>DI5>DI6>DI7>DI8. If any digital inputs is set, the following alarm message will be displayed: "A0750: Set a DI for Function 1 of the Application (Start)" and the operation of the application will not be enabled.

The Stop command is also done by one of digital inputs (DI1 to DI8). However, it is necessary to set one the DI's parameters (P0263 to P0270) to 21 = Function 2 of the Application. If more than one digital input is set for this function, the logic operation will consider only the command of the high priority level digital input, where: DI1>DI2>DI3>DI4>DI5>DI6>DI7>DI8. If any digital inputs is set, the following alarm message will be displayed: "A0752: Set a DI for Function 2 of the Application (Stop)" and the operation of the application will not be enabled.

Both Start and Stop inputs are active when 24 V is applied and inactive when 0 V is applied.

With the inverter enabled in local or remote mode, with no fault, without undervoltage, no A0750 and A0752 alarm, the "General Enable" command is performed in the inverter. In case some digital input is set to "General Enable" function, the inverter will effectively be enabled when the two command sources are active.



NOTE!

In case the 3-Wire command application (Start/Stop) has been selected to operate in local mode and DI1 (P0263) is selected for the Start or Stop command, the inverter may go to the "configuration (CONF)" status; then it is necessary to change the default programming of parameter P0227.

P1010 - Version of the 3-Wire Start/Stop Application

Adjustable Range:	0.00 to 10.00	Factory Setting:	-
Properties:	ro		
Access Groups via HMI:	<input type="text" value="SPLC"/>		

Description:

Read only parameter that presents the software version of the 3-Wire Start/Stop application developed for the SoftPLC function of the CFW700.

4.2.5 Forward/Reverse Run Application

The CFW700 has the Forward/Reverse Run application that allows the combination of two inverter commands (Forward/Reverse and Start/Stop) in a single digital input.

This way, the digital input (Dlx) programmed to “Function 1 of the Application (Forward)” combines the forward rotation with the start/stop command and the input (Dlx) programmed to “Function 2 of the Application (Reverse)” combines the reverse rotation with the start/stop command. The picture below show how it works.

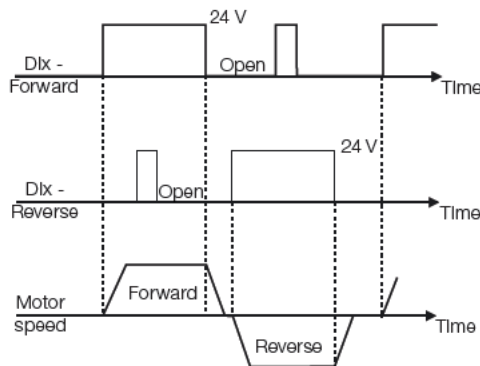

Figure 4.8: Operation of the Forward/Reverse Run application

It is necessary to set the parameter P0223 to 9 = SoftPLC (CW) or 10 = SoftPLC (CCW) together with P0224 to 4 = SoftPLC, or else, it is necessary to set P0226 to 9 = SoftPLC (CW) or 10 = SoftPLC (CCW) together with P0227 to 4 = SoftPLC for the operation of the Forward/Reverse Run application. The following alarm message will be displayed in case the Local FWD/REV selection is not set (P0223): “A0760: Set Local FWD/REV to SoftPLC” and the operation of the application will not be enabled if the Local Run/Stop selection (P0224) has been set to SoftPLC. The same applies to the Remote FWD/REV (P0226), i.e., the following alarm message will be displayed: “A0762: Set Remote FWD/REV to SoftPLC” and the operation of the application will not be enabled if the Remote Run/Stop selection (P0227) has been set to SoftPLC.

Definitions:

- The Function 1 of the Application at parameters P0263 to P0270 represents the Forward command.
- The Function 2 of the Application at parameters P0263 to P0270 represents the Reverse command.

The Forward command is done by one of the digital inputs (DI1 to DI8). It is necessary to set one of the DI's parameters (P0263 to P0270) to 20 = Function 1 of the Application. If more than one digital input is set for this function, the logic operation will consider only the command of the high priority level digital input, where: DI1>DI2>DI3>DI4>DI5>DI6>DI7>DI8. If any digital inputs is set, the following alarm message will be displayed: "A0750: Set a DI for Function 1 of the Application (Forward)" and the operation of the application will not be enabled. It is defined that the forward command rotation will always be "clockwise".

The Reverse command is also done by one of digital inputs (DI1 to DI8). However, it is necessary to set one the DI's parameters (P0263 to P0270) to 21 = Function 2 of the Application. If more than one digital input is set for this function, the logic operation will consider only the command of the high priority level digital input, where: DI1>DI2>DI3>DI4>DI5>DI6>DI7>DI8. If any digital inputs is set, the following alarm message will be displayed: "A0752: Set a DI for Function 2 of the Application (Reverse)" and the operation of the application will not be enabled. It is defined that the forward command rotation will always be "counterclockwise".

Both Forward and Reverse inputs are active when 24 V is applied and inactive when 0V is applied.

With the inverter enabled in local or remote mode, with no fault, without undervoltage, no A0750, A0752, A0760 and A0762 alarms, the "General Enable" command is performed in the inverter. In case some digital input is set to "General Enable" function, the inverter will effectively be enabled when the two command sources are active.

With the forward digital input active and the reverse digital input inactive, the forward and start commands are performed. If the reverse digital input is active, nothing is changed in the operation of the inverter. When both commands are inactive, the start command is removed and the motor will be decelerated to 0 rpm. However, when the reverse digital input is active and the forward digital input is inactive, the reverse and start command are performed. If the forward digital input is active, nothing is changed in the operation of the inverter. When both commands are inactive, the start command is removed and the inverter decelerates to 0 rpm. In case both forward and reverse digital inputs are active at the same time, the forward command will be generated.



NOTE!

In case the Forward/Reverse command was selected to operate in local mode and DI1 (P0263) is selected for the Forward or Reverse command, the inverter may go to the "configuration (CONF)" status; then it is necessary to change the default programming of parameter P0227.

P1010 - Version of the Forward/Reverse Run Application

Adjustable Range:	0.00 to 10.00	Factory Setting:	-
Properties:	ro		
Access Groups via HMI:	<input type="text" value="SPLC"/>		

Description:

Read only parameter that presents the software version of the Forward/Reverse Run application developed for the SoftPLC function of the CFW700.

5 FIRST TIME POWER-UP AND START-UP

5.1 PREPARE FOR START-UP

The inverter shall have been already installed according to the recommendations listed in [Chapter 3 INSTALLATION AND CONNECTION](#) on page 10.



DANGER!

Always disconnect the main power supply before performing any inverter connection.

1. Check if power, grounding, and control connections are correct and firmly secured.
2. Remove from the inside of the inverter all installation material left behind.
3. Verify the motor connections and if the motor voltage and current is within the rated value of the inverter.
4. Mechanically uncouple the motor from the load:
If the motor cannot be uncoupled, make sure that the chosen direction of rotation (forward or reverse) will not result in personnel injury and/or equipment damage.
5. Return the inverter covers.
6. Measure the power supply voltage and verify if it is within the range listed in [Chapter 8 TECHNICAL SPECIFICATIONS](#) on page 62.
7. Apply power to the input:
Close the input disconnect switch.
8. Check the result of the first time power-up:
The display should show the monitoring mode and the status LED should light and stay lit in green.









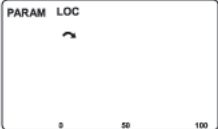

5.2 START-UP

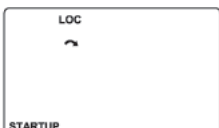















The start-up procedure for the V/f is described in three simple steps by using the STARTUP and BASIC group.

Steps:

- 1 - Set the password for parameter modification.
- 2 - Execute the Oriented Start-up routine (STARTUP group).
- 3 - Set the parameters of the Basic Application group (BASIC).

5.2.1 Oriented Start-up Menu

Step	Action/Display Indication	Step	Action/Display Indication
1	 <ul style="list-style-type: none"> Monitoring mode. Press the ENTER/MENU key to get into the first level of the programming mode. 	2	 <ul style="list-style-type: none"> The PARAM group is selected, press the  or  keys to select the STARTUP group.
3	 <ul style="list-style-type: none"> Press ENTER/MENU when the group is selected. 	4	 <ul style="list-style-type: none"> The parameter "P0317 - Oriented Start-up" is then selected, press the ENTER/MENU to get into the parameter content.
5	 <ul style="list-style-type: none"> Change the parameter P0317 to "1 - Yes", by using the  key. 	6	 <ul style="list-style-type: none"> Press ENTER/MENU to save.
7	 <ul style="list-style-type: none"> In this moment the Oriented Start-up routine is initiated and the "CONF" status is indicated at the keypad (HMI). The parameter "P0000 - Access to Parameters" is selected. Change the password to set the remaining parameters if necessary. The factory default is 5. Press the  key to the next parameter. 	8	 <ul style="list-style-type: none"> If necessary, change "P0296 - Line Rated Voltage". This change will affect P0151, P0153, P0185, P0321, P0322, P0323 and P0400. Press the  key to the next parameter.

Step	Action/Display Indication	Step	Action/Display Indication
9	 <ul style="list-style-type: none"> ■ If necessary, change “P0298 - Application” parameter. This change will affect P0156, P0157, P0158, P0401, P0404 and P0410 (this last one only if P0202 = 0, 1 or 2 - V/f modes). The time and level of the IGBT overload protection will also be affected. ■ Press the  key to the next parameter. 	10	 <ul style="list-style-type: none"> ■ If necessary, change “P0202 - Control Type” parameter. This guide will only show the setting for P0202 = 0 (V/f 60 Hz) or P0202 = 1 (V/f 50 Hz). Refer to the programming manual for other settings (V/f Adjustable, VVW or Vector Modes). ■ Press the  key to the next parameter.
11	 <ul style="list-style-type: none"> ■ If necessary, change “P0398 - Motor Service Factor” parameter. This change will affect the current and the time of the motor overload protection operation. ■ Press the  key to the next parameter. 	12	 <ul style="list-style-type: none"> ■ If necessary, change “P0400 - Motor Rated Voltage” parameter. This change corrects the output voltage by the factor “x = P0400/P0296”. ■ Press the  key to the next parameter.
13	 <ul style="list-style-type: none"> ■ If necessary, change “P0401 - Motor Rated Current” parameter. This change will affect P0156, P0157, P0158 and P0410. ■ Press the  key to the next parameter. 	14	 <ul style="list-style-type: none"> ■ If necessary, change “P0404 - Motor Rated Power” parameter. This change will affect P0410. ■ Press the  key to the next parameter.
15	 <ul style="list-style-type: none"> ■ If necessary, change “P0403 - Motor Rated Frequency” parameter. This change will affect P0402. ■ Press the  key to the next parameter. 	16	 <ul style="list-style-type: none"> ■ If necessary, change “P0402 - Motor Rated Speed”. This change will affect P0122 to P0131, P0133, P0134, P0135, P0182, P0208, P0288 and P0289. ■ Press the  key to the next parameter.







Step	Action/Display Indication	Step	Action/Display Indication
17	 <ul style="list-style-type: none"> ■ If necessary, change “P0405 - Encoder Pulse Number” according to the encoder model. ■ Press the  key to the next parameter. 	18	 <ul style="list-style-type: none"> ■ If necessary, change “P0406 - Motor Ventilation” parameter. ■ Press the  key to the next parameter. ■ The parameters to come after selecting P0406 may vary according to the type of control set at P0202.
19	 <ul style="list-style-type: none"> ■ If necessary, change “P0408 - Run Self-Tuning” parameter. ■ Press the  key to the next parameter. ■ Run the self-tuning when running in VVW and vector modes. 	20	 <ul style="list-style-type: none"> ■ Press the BACK/ESC key to end the oriented start-up routine. ■ Press the BACK/ESC again to go back to the monitoring mode.

Figure 5.1: Oriented Start-up

5.2.2 Basic Application Menu











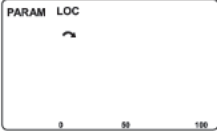

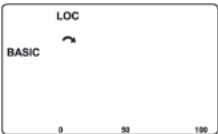









Step	Action/Display Indication	Step	Action/Display Indication
1	 <ul style="list-style-type: none"> Monitoring mode. Press the ENTER/MENU key to get into the first level of the programming mode. 	2	 <ul style="list-style-type: none"> The PARAM group is selected, press the  or  keys to select the BASIC group.
3	 <ul style="list-style-type: none"> Press ENTER/MENU when the group is selected. 	4	 <ul style="list-style-type: none"> In this moment the Basic Application routine is initiated. If necessary, change "P0100 - Acceleration Time" parameter. Press the  or  key to the next parameter.
5	 <ul style="list-style-type: none"> If necessary, change "P0101 - Deceleration Time". Press the  or  key to the next parameter. 	6	 <ul style="list-style-type: none"> If necessary, change "P0133 - Minimum Speed" parameter. Press the  or  key to the next parameter.
7	 <ul style="list-style-type: none"> If necessary, change "P0134 - Maximum Speed" parameter. Press the  or  key to the next parameter. 	8	 <ul style="list-style-type: none"> If necessary, change "P0135 - Max. Output Current" parameter. Press the  or  key to the next parameter.
9	 <ul style="list-style-type: none"> If necessary, change "P0136 - Manual Torque Boost" parameter. Press the  or  key to the next parameter. 	10	 <ul style="list-style-type: none"> Press the BACK/ESC key to end the Basic Application routine. Press the BACK/ESC again to go back to the monitoring mode.

Figure 5.2: Basic application group

6 TROUBLESHOOTING AND MAINTENANCE

6.1 FAULTS AND ALARMS

NOTE!

Refer to the CFW700 quick reference guide and the programming manual for more information about the errors and alarms.

6.2 SOLUTIONS FOR THE MOST FREQUENT PROBLEMS

Table 6.1: Solutions for the most frequent problems

Problem	Point to be Verified	Corrective Action
Motor does not start	Incorrect wiring connection	1. Check all power and control connections.
	Analog reference (if used)	1. Check if the external signal is properly connected. 2. Check the status of the control potentiometer (if used).
	Incorrect settings	1. Check if parameters are properly set for the application.
	Fault	1. Check if the inverter is not blocked due to a fault condition. 2. Check if terminals XC1:15 and 16 and/or XC1:34 and 36 are not shorted (short-circuit at the 24 Vdc power supply).
	Motor stall	1. Decrease motor overload. 2. Increase P0136, P0137 (V/f), or P0169/P0170 (vector control).
Motor speed fluctuates (oscillates)	Loose connection	1. Stop the inverter, turn off the power supply, and check and tighten all power connections. 2. Check all internal connections of the inverter.
	Defective reference potentiometer	1. Replace potentiometer.
	Oscillation of the external analog reference	1. Identify the cause of the oscillation. If it is caused by electrical noise, use shielded cables or separate from the power and control wiring.
	Incorrect settings (vector control)	1. Check parameters P0410, P0412, P0161, P0162, P0175, and P0176. 2. Refer to the programming manual.
Motor speed too high or too low	Incorrect settings (reference limits)	1. Check if the values of P0133 (Minimum Speed) and P0134 (Maximum Speed) are properly set for the motor and application used.
	Control signal from the analog reference (if used)	1. Check the level of the reference control signal. 2. Check the settings (gain and offset) of parameters P0232 to P0240.
	Motor nameplate	1. Check if the motor has been properly sized for the application.
Motor does not reach the rated speed, or motor speed starts oscillating around the rated speed (Vector Control)	Settings	1. Decrease P0180. 2. Check P0410.

Problem	Point to be Verified	Corrective Action
Off display	Keypad connections	1. Check the inverter keypad connection.
	Power supply voltage	1. Rated values shall be within the limits specified below: 200...240 V power supply: (Frame sizes A to D) Minimum: 170 V; Maximum: 264 V. 220 / 230 V power supply: (Frame size E) Minimum: 187 V; Maximum: 253 V. 380...480 V power supply: Minimum: 323 V; Maximum: 528 V. 500...600 V power supply: Minimum: 425 V; Maximum: 660 V.
	Mains supply fuses open	1. Replace fuses.
Motor does not operate in the field weakening region (Vector Control)	Settings	1. Decrease P0180.
Low motor speed and P0009 = P0169 or P0170 (motor operating with torque limitation), for P0202 = 5 - vector with encoder	Encoder signals are inverted or power connection is inverted	1. Check the signals \bar{A} - A, \bar{B} - B, refer to Figura 3.6 on page 21 . If signals are properly installed, exchange two of the output phases. For instance U and V.
	Encoder cable is broken	1. Replace the cable.

6.3 INFORMATION FOR CONTACTING TECHNICAL SUPPORT

For technical support and servicing, it is important to have the following information in hand:

- Inverter model.
- Serial number and manufacturing date available on the identification label of the product (refer to [Section 2.5 IDENTIFICATION LABELS on page 8](#) and the [Figure A.2 on page 208](#)).
- Installed software version (check parameter P0023).
- Application data and inverter settings.

6.4 PREVENTIVE MAINTENANCE



DANGER!

Always disconnect the general power supply before touching any electric component associated to the inverter.

High voltages can be present even after the disconnection of the power supply. Wait for at least 10 minutes for the complete discharge of the power capacitors. Always connect the frame of the equipment to the protective earth (PE) at the proper point.



ATTENTION!

The electronic cards have components sensitive to electrostatic discharges. Do not touch directly on the components or connectors. If necessary, first touch the grounded metallic frame or use proper grounding strap.

Do not execute any applied potential test on the inverter!
If necessary, contact WEG.

Table 6.2: Preventive maintenance

Maintenance		Interval	Instructions
Fan replacement		After 50.000 hours of operation. ⁽¹⁾	Replacement procedure shown in Figure 6.1 on page 58 and Figure 6.2 on page 58 .
Electrolytic capacitors	If the Inverter is stocked (not in use): "Reforming"	Every year from the manufacturing date printed on the Inverter Identification label (refer to Chapter 2 GENERAL INSTRUCTIONS on page 3).	Apply power to the Inverter with voltage between 220 and 230 Vac, single-phase or three-phase, 50 or 60 Hz, for at least one hour. Then, disconnect the power supply and wait for at least 24 hours before using the Inverter (reapply power).
	Inverter being used: replace	Every 10 years.	Contact WEG technical support to obtain replacement procedure.

(1) The Inverters are set at the factory for automatic control of the fans (P0352 = 2), so that they are only started when the temperature of the heatsink increases. Therefore number of operating hours of the fans will depend on the operating conditions (motor current, output frequency, temperature of the refrigeration air, etc.). The Inverter records in P0045 the number of hours the fan remained ON. When the fan reaches 50,000 hours of operation, the HMI display will show the alarm A0177.

Table 6.3: Periodic inspection at every 6 months

Component	Abnormality	Corrective Action
Terminals, connectors	Loose screws	Tighten
	Loose connectors	
Fans /Cooling systems	Dirty fans	Cleaning
	Abnormal acoustic noise	Replace fan. See Figure 6.1 on page 58 and Figure 6.2 on page 58 . Check fan connections
	Blocked fan	
	Abnormal vibration	
	Dust in the panel air filters	Cleaning or replacement
Printed circuit boards	Accumulation of dust, oil, humidity, etc.	Cleaning
	Odor	Replacement
Power module/ Power connections	Accumulation of dust, oil, humidity, etc.	Cleaning
	Loose connection screws	Tightening
Capacitors of the DC link (Intermediate Circuit)	Discoloration/ odor / electrolyte leakage	Replacement
	Safety valve expanded or broken	
	Frame expansion	
Power resistors	Discoloration	Replacement
	Odor	
Heatsink	Accumulation of dust	Cleaning
	Dirt	

6.5 CLEANING INSTRUCTIONS

When it is necessary to clean the inverter, follow the instructions below:

- Ventilation system:
 - Disconnect the power supply of the inverter and wait for 10 minutes.
 - Remove de dust accumulated in the ventilation opening using a plastic brush or cloth.
- Remove the dust accumulated on the fins of the heatsink and fan blades using compressed air.
- Electronic boards:
 - Disconnect the power supply of the inverter and wait for 10 minutes.
- Remove the dust accumulated on the boards using an anti-static brush or ion compressed air gun (Example: Charge Buster Ion Gun (non nuclear) reference A6030-6DESCO).

If necessary, remove the boards from the inverter.

Always use grounding strap.

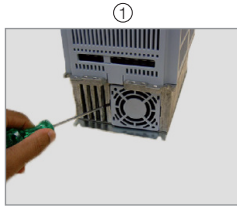

Release of the locks of the fan cover

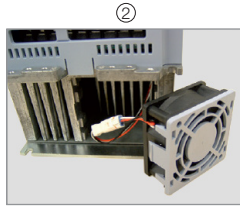

Removal of the fan

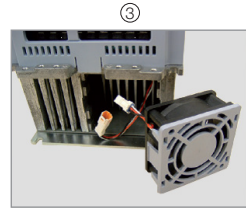

Cable disconnection

(a) Models of frame sizes A, B, C, D and model 105 A / 380 / 480 V

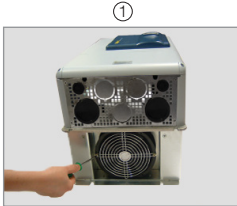

Removal of the fan grid screws

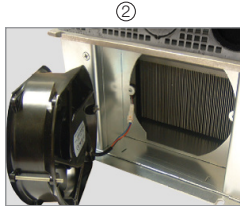

Removal of the fan

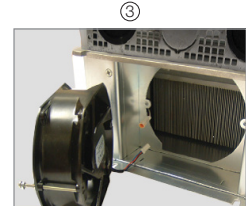

Cable disconnection

(b) Models 142 A, 180 A and 211 A / 220 / 230 V and 380 / 480 V and all the models of 500 / 600 V

Figure 6.1: (a) and (b) Removal of the heatsink fan

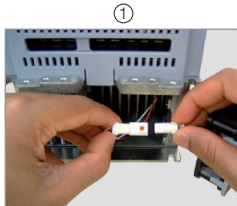

Cable connection

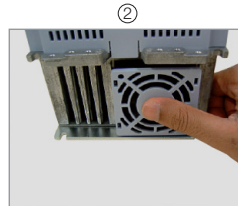

Plugging in of the fan

(a) Models of frame sizes A, B, C, D and model 105 A / 380 / 480 V

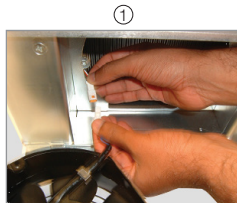

Cable connection

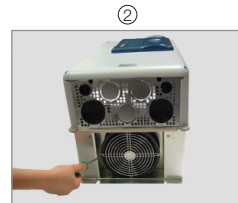

Fastening of the fan and grid to the product

(b) Models 142 A, 180 A and 211 A / 220 / 230 V and 380 / 480 V and all the models of 500 / 600 V

Figure 6.2: (a) and (b) Installation of the heatsink fan

7 OPTION KITS AND ACCESSORIES

7.1 OPTION KITS

Some models cannot incorporate all available option kits. Refer to [Table 2.2 on page 7](#) for a detailed description of the option kits that are available for each inverter model.

7.1.1 Built-in RFI Filter (only for frame sizes A, B, C and D) - CFW700...C3...

Reduces the electrical noise from the inverter to the power supply (conducted emissions) in the high frequency range (> 150 kHz), necessary to accomplish with the maximum levels of conducted emission specified in the electromagnetic compatibility standards (EN 61800-3 and EN 55011). Refer to [Section 3.3 INSTALLATION ACCORDING TO THE EUROPEAN DIRECTIVE OF ELECTROMAGNETIC COMPATIBILITY on page 24](#), for more details.

7.1.2 Dynamic Braking IGBT (only for frame size E in 220 / 230 V and 380...480 V models and for frame sizes D and E in 500...600 V models) - CFW700...DB...

Refer to [Item 3.2.3.3 Dynamic Braking \(standard built-in for frame sizes A, B, C and D and optional built-in for frame size E - CFW700...DB...\) on page 16](#), for more details about the Dynamic Braking.

7.1.3 Nema1 Protection Degree (only for frame sizes A, B, C and E) - CFW700...N1...

Inverter with Nema1 enclosure. Refer to [Figure B.2 on page 240](#). These inverters have the KN1X-02 kit (refer to [Section 7.2 ACCESSORIES on page 60](#)).

7.1.4 IP55 Protection Degree (only for frame sizes B and C) - CFW700...55...

Inverter with IP55 enclosure. Refer to [Figure A.10 on page 216](#). These inverters have the PCSC-03 kit (refer to [Section 7.2 ACCESSORIES on page 60](#)).

7.1.5 IP21 Protection Degree (only for frame sizes A, B and C) - CFW700...21...

Inverter with IP21 enclosure. Refer to [Figure A.9 on page 215](#). These inverters have the KIP21X-01 kit (refer to [Section 7.2 ACCESSORIES on page 60](#)).

7.1.6 STO Function - CFW700...Y1...

The STO function complies with the requirements of category 3 (PL d) according to EN ISO 13849-1, SIL CL 2 according to IEC 61800-5-2 / IEC 62061 / IEC 61508 and can be used in applications up to category 3 (PL d) according to EN ISO 13849-1 and SIL 2 according to IEC 62061 / IEC 61508. Refer to the guide supplied with the product for more information.



NOTE!

It is not possible to assemble the top cover on inverters of mechanics A that have optional safety stop. Thus, it is not possible to raise the protection level of these inverters to IP21 or Nema1.

7.1.7 24 Vdc External Control Power Supply - CFW700...W1...

The use of this option kit is recommended with communication networks (Profibus, DeviceNet, etc.), since the control circuit and the network communication interface are kept active (with power supply and responding to the network communication commands) even in the event of main power supply interruption.

Inverters with this option have a built-in DC/DC converter with a 24 Vdc input that provides adequate outputs for the control circuit. Therefore, the control circuit power supply will be redundant, i.e., it can be provided either by a 24 Vdc external power supply (connection as shown in [Figure 7.1 on page 60](#) a) or b)) or by the standard internal switched mode power supply of the inverter.

Observe that the inverters with the external 24 Vdc power supply option use terminals XC1:34 and 36 or XC1:15 and 16 as the input for the external power supply and no longer as the output like in the standard inverter ([Figure 7.1 on page 60](#)).

In case of interruption of the external 24 Vdc power supply, the digital inputs/outputs and analog outputs will no longer be fed, even if the mains power is on. Therefore, it is recommended to keep the 24 Vdc power supply always connected to the terminals XC1:34 and 36 or XC1:15 and 16.

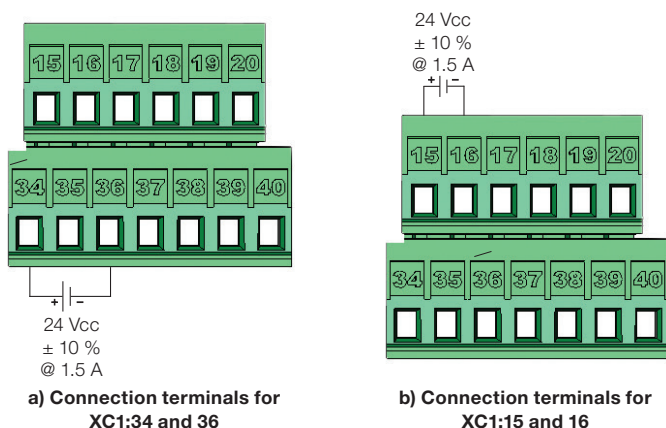

Figure 7.1: External 24 Vdc power supply capacity and connection terminals

7.2 ACCESSORIES

The accessories are installed to the inverter easily and quickly using the “Plug and Play” concept. When an accessory is connected to the slots, the control circuit automatically identifies the model of this accessory and its code is presented in the parameter P0028. The accessory shall be installed with the inverter power supply off.

The code and model of each available accessory is presented in the [Table 7.1 on page 61](#). The accessories can be ordered individually and they will be provided in their own packaging containing the components and guides with detailed instructions for installation, operation and programming.

Table 7.1: Accessory models

WEG (part number)	Name	Description	Slot	Identification Parameters - P0028
Control Accessories				
11511558	USB-RS-485/RS-422	USB-RS-485/RS-422 Interface kit.	-	-
11008106	CAN-01	CAN interface module (CANopen / DeviceNet).	3	CD--
11045488	PROFIBUS DP-01	Profibus DP Interface module.	3	C9--
Flash Memory Module				
11355980	MMF-02	FLASH memory module.	5	--xx ⁽¹⁾
Expansion Module				
11402038	CCK-01	Output relays module.	-	-
Stand-alone Keypad, Blank Cover, and Frame for Remote Mounted Keypad				
11401784	HMI-02	CFW700 stand-alone keypad (HMI). ⁽²⁾	HMI	-
11342535	RHMIF-02	Remote keypad frame kit (IP56).	-	-
10950192	1 m HMI Cable	1 m serial remote keypad cable set.	-	-
10951226	2 m HMI Cable	2 m serial remote keypad cable set.	-	-
10951223	3 m HMI Cable	3 m serial remote keypad cable set.	-	-
10951227	5 m HMI Cable	5 m serial remote keypad cable set.	-	-
10951240	7.5 m HMI Cable	7.5 m serial remote keypad cable set.	-	-
10951239	10 m HMI Cable	10 m serial remote keypad cable set.	-	-
11010298	HMID-01	Blank cover for the keypad slot.	HMI	-
Miscellaneous				
11401877	KN1A-02	Nema1 kit for frame size A Inverter. ⁽²⁾	-	-
11401938	KN1B-02	Nema1 kit for frame size B Inverter. ⁽²⁾	-	-
11401857	KN1C-02	Nema1 kit for frame size C Inverter. ⁽²⁾	-	-
10960842	KN1E-01	Nema1 kit for models 105 A and 142 A of frame size E Inverter. ⁽²⁾	-	-
10960850	KN1E-02	Nema1 kit for models 180 and 211 A of frame size E Inverter. ⁽²⁾	-	-
11401939	KIP21A-01	IP21 kit for frame size A Inverter.	-	-
11401941	KIP21B-01	IP21 kit for frame size B Inverter.	-	-
11401940	KIP21C-01	IP21 kit for frame size C Inverter.	-	-
11010264	KIP21D-01	IP21 kit for frame size D Inverter.	-	-
11010265	PCSA-01	Kit for power cables shielding - frame size A.	-	-
11010266	PCSB-01	Kit for power cables shielding - frame size B.	-	-
11010267	PCSC-01	Kit for power cables shielding - frame size C.	-	-
11119781	PCSD-01	Kit for power cables shielding - frame size D (Included in the standard product).	-	-
10960844	PCSE-01	Kit for power cables shielding - frame size E (Included in the standard product).	-	-
12705234	PCBC-01	Kit for power cables shielding - frame sizes B and C with degree of protection IP55.	-	-
13231750	PCSD-02	Power cable shielding kit for frame size D with IP55 degree of protection.	-	-
10960847	CCS-01	Kit for control cables shielding (Included in the standard product).	-	-
11401942	CONRA-02	CFW700 Control Rack (Includes the CC700.CDE control board and it is supplied with the product).	-	-
10790788	DBW030380D3848SZ	380...480 Vac dynamic braking module.	-	-
10794631	DBW030250D5069SZ	500...690 Vac dynamic braking module.	-	-

Notes:

- (1) The identification of the MMF-02 module is presented in the bit 6 of the parameter P0028. Refer to CFW700 programming manual.
- (2) Use DB-9 pin, male-to-female, straight-through cable (serial mouse extension type) for connecting the keypad to the Inverter or Null-Modem standard cable. Maximum cable length: 10 m (33 ft).
Examples:
 - Mouse extension cable - 1.80 m (6 ft); Manufacturer: Clone.
 - Belkin pro series DB9 serial extension cable 5 m (17 ft); Manufacturer: Belkin.
 - Cables Unlimited PCM195006 cable, 6 ft DB9 m/f; Manufacturer: Cables Unlimited.

(3) Refer to [Figure B.2 on page 240](#).

8 TECHNICAL SPECIFICATIONS

8.1 POWER DATA

Power Supply:

- Maximum rated voltage: 240 V for 200...240 V models, 230 V for 220 / 230 V models and 480 V for 380...480 V models and 600 V for 500...600 models up to 2000 m height. It is necessary to apply 1.1 % voltage derating every 100 m (328 ft) above 2000 m (6562 ft), limited to 4000 m (13123 ft).
- Remaining specifications according to user's manual.
- Voltage tolerance: -15 % to +10 % of the nominal voltage.
- Frequency: 50 / 60 Hz (48 Hz to 62 Hz).
- Phase imbalance: ≤ 3 % of the rated phase-to-phase input voltage.
- Overvoltage according to Category III (EN 61010/UL 508C).
- Transient voltage according to Category III.
- Maximum of 60 connections per hour (1 per minute).
- Efficiency: according to class IE2 as per EN 50598-2.
- Typical input power factor:
 - 0.94 for three-phase power supply models in the rated conditions.
 - 0.70 for single-phase power supply models in the rated conditions.
 - $\cos \varphi$ (displacement factor): > 0.98 .

Refer to [APPENDIX B - TECHNICAL SPECIFICATIONS](#) on page 218 for more information about the technical specifications.

8.2 ELECTRICAL/GENERAL SPECIFICATIONS

Table 8.1: Electrical/general specifications

CONTROL	METHOD	<ul style="list-style-type: none"> ■ Voltage source. ■ Type of control: <ul style="list-style-type: none"> - V/f (Scalar). - VVW: Voltage Vector Control. - Vector control with encoder. - Sensorless vector control (without encoder). ■ PWM SVM (Space Vector Modulation). ■ Full digital (software) current, flux, and speed regulators. Execution rate: <ul style="list-style-type: none"> - current regulators: 0.2 ms (5 kHz). - flux regulator: 0.4 ms (2.5 kHz). - speed regulator / speed measurement: 1.2 ms.
	OUTPUT FREQUENCY	<ul style="list-style-type: none"> ■ 0 to 3.4 x rated motor frequency (P0403). The rated motor frequency is programmable from 0 Hz to 300 Hz in the V/f and VVW modes and from 30 Hz to 120 Hz in the vector mode. ■ Maximum output frequency limit according to the switching frequency: <ul style="list-style-type: none"> - 125 Hz (switching frequency = 1.25 kHz). - 250 Hz (switching frequency = 2.5 kHz). - 500 Hz (switching frequency ≥ 5 kHz).
PERFORMANCE	SPEED CONTROL	<p>V/f (Scalar):</p> <ul style="list-style-type: none"> ■ Regulation (with slip compensation): 1 % of the rated speed. ■ Speed variation range: 1:20. <p>VVW:</p> <ul style="list-style-type: none"> ■ Regulation: 1 % of the rated speed. ■ Speed variation range: 1:30. <p>Sensorless:</p> <ul style="list-style-type: none"> ■ Regulation: 0,5 % of the rated speed. ■ Speed variation range: 1:100. <p>Vector with Encoder:</p> <ul style="list-style-type: none"> ■ Regulation: <ul style="list-style-type: none"> - ±0.1 % of the rated speed with a digital reference (keypad, serial, fieldbus, Electronic Potentiometer, Multispeed). - ±0.2 % of the rated speed with a 12-bits analog input.
PERFORMANCE	TORQUE CONTROL	<ul style="list-style-type: none"> ■ Range: 10 to 180 %, regulation: ±5 % of the rated torque (with encoder). ■ Range: 20 to 180 %, regulation: ±10 % of the rated torque (sensorless above 3 Hz).
USER'S POWER SUPPLIES (CC700 board)	REF (XC1:21-24)	<ul style="list-style-type: none"> ■ 10 V ± 10 % power supply to be used with the potentiometer at the analog inputs. ■ Maximum output current: 2 mA.
	+5V-ENC (XC1:1-8)	<ul style="list-style-type: none"> ■ 5 V ± 5 % power supply for the encoder. ■ Maximum output current: 160 mA.
	+24 V	<ul style="list-style-type: none"> ■ 24 V ± 10 % power supply to be used with the digital inputs/outputs. ■ Maximum output current: 500 mA.
INPUTS (CC700 board)	ANALOG	<ul style="list-style-type: none"> ■ 2 differential inputs. ■ Resolution: 11 bits + signal. ■ Input levels: (0 to 10) V, (-10 to 10) V, (0 to 20) mA or (4 to 20) mA. ■ Impedance: 400 kΩ for the voltage input, 500 Ω for the current input. ■ Maximum input voltage: ± 15 V. ■ Programmable functions.
	DIGITAL	<ul style="list-style-type: none"> ■ 8 isolated digital inputs. ■ 24 Vdc (High level ≥ 10 V, Low level ≤ 2 V). ■ Maximum input voltage: ± 30 Vdc. ■ Input impedance: 2 kΩ. ■ Active high or active low input selectable by jumper (simultaneous selection for all inputs).

OUTPUTS (CC700 board)	ANALOG	<ul style="list-style-type: none"> ■ 2 non isolated outputs. ■ Voltage (0 to 10 V) or current (0/4 mA to 20 mA) output. ■ Maximum load: $R_L \geq 10 \text{ k}\Omega$ (voltage) or $R_L \leq 500 \Omega$ (current). ■ Resolution: 10 bits. ■ Programmable functions.
	RELAY	<ul style="list-style-type: none"> ■ 1 relay (NO/NC). ■ Maximum voltage: 240 Vac / 30 Vdc. ■ Maximum current: 0.75 A. ■ Programmable functions.
	TRANSISTOR	<ul style="list-style-type: none"> ■ 4 open collector isolated digital outputs (with the same reference as the 24 V power supply). ■ Maximum current: 80 mA. ■ Maximum voltage: 30 Vdc. ■ Programmable functions. <p>Note: When the load of the digital output is fed by an external power supply, the output status remains indefinite until the internal 24 V power supply becomes stable.</p>
SAFETY	PROTECTION	<ul style="list-style-type: none"> ■ Output overcurrent/short-circuit. ■ Under/Overvoltage. ■ Phase loss. ■ Overtemperature of the heatsink/internal air. ■ IGBTs overload. ■ Motor overload. ■ External fault / alarm. ■ CPU or memory fault. ■ Output phase-ground short-circuit.
INTEGRAL KEYPAD (HMI)	STANDARD KEYPAD	<ul style="list-style-type: none"> ■ 9 operator keys: Start/Stop, Up arrow, Down arrow, Direction of rotation, Jog, Local/Remote, BACK/ESC and ENTER/MENU. ■ LCD display. ■ View/edition of parameters. ■ Indication accuracy: <ul style="list-style-type: none"> - current: 5 % of the rated current. - speed resolution: 1 rpm. ■ Possibility of remote mounting. ■ USB communication port. ⁽¹⁾
ENCLOSURE	IP20	<ul style="list-style-type: none"> ■ Frame sizes A, B and C inverters without the top cover and with Nema1 kit. ■ Frame size E inverters without Nema1 kit.
	NEMA1/IP20	<ul style="list-style-type: none"> ■ Frame size D inverters without IP21 kit. ■ Frame size E inverters with Nema1 kit (KN1E-01 or KN1E-02).
	IP21	<ul style="list-style-type: none"> ■ Frame sizes A, B and C inverters with top cover.
	NEMA1/IP21	<ul style="list-style-type: none"> ■ Frame sizes A, B and C inverters with top cover and with Nema1 kit. ■ Frame size D inverters with IP21 kit.
	IP54	<ul style="list-style-type: none"> ■ Rear part of the inverter (external part for flange mounting). ■ Rear of the inverter with degree of protection IP20 (external part for flange mount). ⁽²⁾
	IP55	<ul style="list-style-type: none"> ■ Frame sizes B, C, D and E.

(1) Available from the serial number 1024003697.

(2) Models 180 A and 211 A with 220 / 230 V and 380...480 V power supply, and models 125 A and 150 A with 500...600 V power supply require special hardware H1.

8.3 CODES AND STANDARDS

Table 8.2: Codes and standards

SAFETY STANDARDS	<ul style="list-style-type: none"> ■ UL 508C - Power conversion equipment. ■ Note: Suitable for installation in a compartment handling conditioned air. ■ UL 840 - Insulation coordination including clearances and creepage distances for electrical equipment. ■ EN61800-5-1 - Safety requirements electrical, thermal and energy. ■ EN 50178 - Electronic equipment for use in power installations. ■ EN 60204-1 - Safety of machinery. Electrical equipment of machines. Part 1: General requirements. ■ Note: The final assembler of the machine is responsible for installing an safety stop device and a supply disconnecting device. ■ EN 60146 (IEC 146) - Semiconductor converters. ■ EN 61800-2 - Adjustable speed electrical power drive systems - Part 2: General requirements - Rating specifications for low voltage adjustable frequency AC power drive systems.
ELECTROMAGNETIC COMPATIBILITY (EMC)	<ul style="list-style-type: none"> ■ EN 61800-3 - Adjustable speed electrical power drive systems - Part 3: EMC product standard including specific test methods. ■ CISPR 11 - Industrial, scientific and medical (ISM) radio-frequency equipment - Electromagnetic disturbance characteristics - Limits and methods of measurement. ■ EN 61000-4-2 - Electromagnetic compatibility (EMC) - Part 4: Testing and measurement techniques - Section 2: Electrostatic discharge immunity test. ■ EN 61000-4-3 - Electromagnetic compatibility (EMC) - Part 4: Testing and measurement techniques - Section 3: Radiated, radio-frequency, electromagnetic field immunity test. ■ EN 61000-4-4 - Electromagnetic compatibility (EMC) - Part 4: Testing and measurement techniques - Section 4: Electrical fast transient/burst immunity test. ■ EN 61000-4-5 - Electromagnetic compatibility (EMC) - Part 4: Testing and measurement techniques - Section 5: Surge immunity test. ■ EN 61000-4-6 - Electromagnetic compatibility (EMC) - Part 4: Testing and measurement techniques - Section 6: Immunity to conducted disturbances, induced by radio-frequency fields.
MECHANICAL STANDARDS	<ul style="list-style-type: none"> ■ EN 60529 - Degrees of protection provided by enclosures (IP code). ■ UL 50 - Enclosures for electrical equipment.

8.4 CERTIFICATIONS

Certifications (*)	Notes
UL and cUL	E184430
CE	
IRAM	
C-Tick	
EAC	
Functional Safety	STO Funtion, with certificate issued by TÜV Rheinland

(*) For updated information on certifications, please contact WEG.